

Common User Data

Machine Name: Xerox EC8136 Color MFP (9D:A2:3C)
 IP Address: 10.61.12.190
 Machine Serial Number: MQ5010507
 Fax Line 1: 3337
 Machine URL: https://10.61.12.190
 Machine Activation Date: Jan 14, 2025 @1:29:18
 Black Impressions: 313
 Color Impressions: 743
 Total Impressions: 1056

Machine Profile

Xerox Asset Tag:
 Customer Asset Tag:
 Service Phone Number:
 Customer Support Number:
 Supplies Phone Number:
 System Administrator: Not set
 Machine Location: machine location not set

Managed By

Primary MB Server:

Machine Hardware

Fax Card: Embedded; 2 Lines
 Fax Memory Size: 966 MB
 Foreign Interface Card: not present
 Device RAM Size: 4096 MB
 Device Storage Size: used=3319MB/total=500107MB (HDD)
 EPC Memory Size: 900 MB
 Finisher Type: BR Booklet Maker Finisher
 Finisher Punch: 2/4 Hole
 Finisher Folder: not present
 Multi-feed Detection Kit: Not Installed

General Setup

Remote Services: Enabled
 Remote Software Download: Enabled
 Remote Services Trans. Time: 17:34
 Xerox Workplace Cloud: Enabled
 E-mail Alerts: Disabled
 Service Plan: Plan Activated
 Billing Impression Mode: A3 Impressions
 Geographic Region: Western Hemisphere
 GMT Offset: +05:30
 Cloning Installation: Allowed (Encrypted Files Only)
 File Sharing: Enabled
 JBIG2: Lossless

Energy Saver

Deep Sleep: Enabled
 Energy Saver Mode: Job Activated

Smart Proximity Sensor

Wake on Arrival: Enabled
 Sleep on Departure: Disabled

Software Versions

Device Software: 122.043.005.09800
 Patch Version: None
 Network Controller: 122.043.09800
 UI Panel Firmware: 003.004.00000
 Marking Engine: 030.045.000
 Document Feeder: 023.026.000
 Finisher: 006.003.000
 Fax: 003.021.015
 Scanner: 016.024.013

Machine Upgrades:

Last Successful Upgrade: April 9, 2025 18:52:21

Media Trays

Tray 1: Glossy Cardstock, White and A3 (297 x 420...
 Tray 2: Plain, White and Letter (8.5 x 11")
 Tray 3: Plain, White and A4 (210 x 297 mm)
 Tray 4: Plain, White and Letter (8.5 x 11")
 Bypass Tray: Plain, White and x=1200mm, y=310mm

Installed Options

PS: Installed

Connectivity

Mobile Workflows

AirPrint Printing: Enabled
 Mopria Printing: Enabled
 AirPrint / Mopria Scanning: Enabled
 Authentication Required: Disabled

Physical Connections

USB Settings
 USB Type A Ports: All Enabled
 USB Type B Port: Disabled
Wired:
 Ethernet MAC Address: Enabled
 Ethernet Speed/Duplex Setting: 9c:93:4e:9d:a2:3c auto
Wireless:
 Wireless MAC Address: Disabled
 Network Name (SSID):
 BSSID:
 Security Mode:
 Encryption Algorithm:
 Status:

Wi-Fi Direct: Enabled
 Wireless Hardware: Not Installed
 Wi-Fi Protected Setup™ (WPS) Name:
 Access Point (SSID):
 Show Password on Device Touch Screen:
NFC: Enabled
 iBeacon (Bluetooth®) for AirPrint Di...: Enabled
 iBeacon Hardware: Not Installed
 Bluetooth Device Address:
 iBeacon IP Address:

Protocols

TCP/IPv4:

IP Address: 10.61.12.190
 Subnet Mask: 255.255.255.0
 Router/Gateway: 10.61.12.1
 Automatic Addressing: DHCP
 DHCP Server: 10.61.13.224
 DHCP Lease Expiration: Mon Apr 21 10:18:57 2025
 BOOTP Broadcast: Disabled
 Self Assigned Address State: Enabled
 Self Assigned Address:

TCP/IPv6:

Link Local Address: Disabled
 Use Router Supplied Prefix: Enabled
 Stateless Global Address 1: ::
 Stateless Global Address 2: ::
 Manual Address:
 DHCP Addressing: Use DHCP as directed by a router
 DHCP Address:
 Default Gateway:
 DUID (DHCP Unique Identifier):

DNS Settings:

Requested Host Name: XRX9C934E9DA23C
 Verified Host Name:
 Requested Domain Name: xerox.com
 Verified Domain Name:
 Multicast DNS: Enabled
 Release DHCP Leases and DNS Registrati...: Disabled
 Primary DNS Server: 10.61.7.16
 Prefer IPv6 DNS over IPv4: Enabled

Bonjour:

Bonjour Printer Name: Xerox EC8136 Color MFP (9D:A2:3C)

HTTP:

Force Traffic over Secure Connection (H...: Enabled
 IPP: Yes
 Enabled

SNMP

SNMP v1/v2: Enabled
 SNMP v3: Disabled

LPR/LPD:

Enabled

Raw IP Printing:

Enabled

LDAP

LDAP Server 1 Primary LDAP Address: 0.0.0.389
 LDAP Server 1 Search Directory Root:
 LDAP Server 1 Secure Connection (LDA...: Disabled
 LDAP Server 1 Validate Server Certificate...: Disabled

SMTP

SMTP Server: 10.61.23.93.25
 Connect Encryption (TLS): No Encryption
 Validate Server Certificate (TLS):
 SMTP Authentication Type: Basic Auth with SMTP

Protocols (cont.)

POP3	
POP3 Server:	10.61.11.93:110
POP3 Secure Connection (TLS):	Disabled
POP3 Validate Server Certificate:	
E-mail Address:	test@tls13.com
NTP:	Disabled
FTP Client:	Enabled
FTP Client Mode:	Passive
Web Services on Device:	Enabled

Apps**Printing**

Banner Sheet:	Disabled
Error Sheets:	Enabled
Paper Substitution:	Enabled
Tray Priority:	1,2,3,4,5
PostScript	Installed
Level:	3
Version:	3021.101

PCL

Version:	6
Font Name:	Courier
Custom Color Tables	Enabled
Label:	Not Installed

Fax:

Fax Line1:	3337
Fax Line2:	3337

Server Fax:

Repository Protocol:	Enabled
Repository Server:	SMB
Repository Document Path:	0.0.0.0:0

Workflow Scanning:

	Enabled
--	---------

Email:

Scan to Mailbox:	Enabled
Storage Capacity (MB):	23443 MB
Storage Used (MB):	1264 MB
Cleanup of Public Folders:	Enabled
Cleanup of Created Folders:	Enabled
Cleanup Time:	Daily

Scan to Home:

	Disabled
--	----------

Scan To:

	Enabled
--	---------

Cloud Services:

	Disabled
--	----------

Print From:

	Enabled
--	---------

Saved Jobs for Reprint:	Enabled
Print From USB:	Enabled
Print From MailBox:	Disabled
Cloud Services:	Disabled

Accounting

Accounting Mode:	None
Network Accounting:	Disabled

Security**Authentication Configuration**

Machine UI Authentication:	Locally on the Device
Home:	Unlocked
Jobs:	Unlocked
Device:	Unlocked
Device Website Authentication:	Locally on the Device
Authorization:	Locally on the Device
Retrieve E-mail from LDAP:	Enabled

Authentication Server:

	Kerberos
--	----------

Xerox Secure Access:

	Disabled
--	----------

Audit Log:

	Enabled
--	---------

IP Sec:

	Disabled
--	----------

IP Filtering:

	Disabled
--	----------

Security Certificates

Machine Certificate:	Signed
Root Certificates Installed:	54

802.1x:

	Disabled
--	----------

Image Overwrite

Immediate:	Installed/Enabled
Scheduled:	Disabled

FIPS 140-3:

	Disabled
--	----------

TLS:

	TLS 1.2 and TLS 1.3
--	---------------------

TLS Hash:	SHA-1, SHA-256 and above
-----------	--------------------------

Trellix Embedded Control:

	Enhanced Security
--	-------------------

Common User Data

Machine Name: Xerox EC8136 Color MFP (9D-A2:3C)
 IP Address: 10.61.12.190
 Machine Serial Number: MQ5010507
 Fax Line 1: 3337
 Machine URL: https://10.61.12.190
 Machine Activation Date: Jan 14, 2025 01:29:18
 Black Impressions: 313
 Color Impressions: 743
 Total Impressions: 1056

Machine Profile

Xerox Asset Tag:
 Customer Asset Tag:
 Service Phone Number:
 Customer Support Number:
 Supplies Phone Number:
 System Administrator:
 Machine Location:
 Managed By
 Primary MB Server:

Machine Hardware

Fax Card: Embedded; 2 Lines
 Fax Memory Size: 966 MB
 Foreign Interface Card: not present
 Device RAM Size: 4096 MB
 Device Storage Size: used=3319MB/total=500107MB (HDD)
 EPC Memory Size: 900 MB
 Finisher Type: BR Booklet Maker Finisher
 Finisher Punch: 2/4 Hole
 Finisher Folder: not present
 Multi-feed Detection Kit: Not Installed

General Setup

Remote Services: Enabled
 Remote Software Download: Enabled
 Remote Services Trans. Time: 17.34
 Xerox Workplace Cloud: Enabled
 E-mail Alerts: Disabled
 Service Plan: Plan Activated
 Billing Impression Mode: A3 Impressions
 Geographic Region: Western Hemisphere
 Startup Config Report: Enabled
 GMT Offset: +05:30
 Cloning Installation: Allowed (Encrypted Files Only)
 Allow Print Submission of Clone Files: Enabled
 File Sharing: Enabled
 JBIG2: Lossless

Energy Saver

Deep Sleep: Enabled
 Energy Saver Mode: Job Activated
 Sleep Mode Timer: 30 minutes
 Auto-Off: Disabled

Smart Proximity Sensor

Wake on Arrival: Enabled
 Sleep on Departure: Disabled
 Maximize Detection Range: Disabled

Software Versions

Device Software: 122.043.005.09800
 Patch Version: None
 Network Controller: 122.043.09800
 UI Panel Firmware: 003.004.00000
 User Interface: 122.043.09800
 Marking Engine: 030.045.000
 Copy Controller: 122.043.09800
 Document Feeder: 023.026.000
 Finisher: 006.003.000
 Fax: 003.021.015
 OS: 122.005.09800
 Scanner: 016.024.013
 Software Upgrade: 122.043.09800
 Tray 2:
 Tray 3:
 Tray 4:

Machine Upgrades

Allowed
 Last Successful Upgrade: April 9, 2025 18:52:21
 Scheduled Auto Upgrades: Disabled
 Auto Upgrade Start Time: Daily
 Auto Upgrade Server: 0.0.0.21

Media Trays

Tray 1: Glossy Cardstock, White and A3 (297 x 420 mm)
 Tray 2: Plain, White and Letter (8.5 x 11")
 Tray 3: Plain, White and A4 (210 x 297 mm)
 Tray 4: Plain, White and Letter (8.5 x 11")
 Bypass Tray: Plain, White and x=1200mm, y=310mm

Connectivity

Mobile Workflows

AirPrint Printing: Enabled
 Mopria Printing: Enabled
 AirPrint / Mopria Scanning: Enabled
 Authentication Required: Disabled
 Universal Print: Disabled
 Universal Print Registration Status: Not Registered

Physical Connections

USB Settings
 USB Type A Ports: All Enabled
 USB Type B Port: Disabled

Wired:

Ethernet MAC Address: 9c:93:4e:9d:a2:3c
 Ethernet Speed/Duplex Setting: auto

Wireless:

Wireless MAC Address:
 Network Name (SSID):
 BSSID:
 Security Mode:
 Encryption Algorithm:
 Status: Enabled

Wi-Fi Direct:

Wireless Hardware: Not installed

Wi-Fi Protected Setup™ (WPS) Name:

Connection Method:
 Subnet Prefix Address:
 Access Point (SSID):
 Show Password on Device Touch Screen:

NFC:

iBeacon (Bluetooth®) for AirPrint Di...: Enabled
 iBeacon Hardware: Enabled
 Bluetooth Device Address: Not Installed
 iBeacon IP Address:

Protocols

TCP/IPv4:

Enabled
 IP Address: 10.61.12.190
 Subnet Mask: 255.255.255.0
 Router/Gateway: 10.61.12.1
 Automatic Addressing: DHCP
 DHCP Server: 10.61.13.224
 DHCP Lease Expiration: Mon Apr 21 10:18:57 2025
 BOOTP Broadcast: Disabled
 Self Assigned Address State: Enabled

TCP/IPv6:

Disabled
 Link Local Address:
 Use Router Supplied Prefix: Enabled
 Stateless Global Address 1: ::
 Stateless Global Address 2: ::
 Manual Address:
 DHCP Addressing: Use DHCP as directed by a router
 DHCP Address:
 Default Gateway:
 OUI (DHCP Unique Identifier):

DNS Settings:

Requested Host Name: XRX9C934E9DA23C
 Verified Host Name:
 Requested Domain Name: xeroxqa.com.
 Verified Domain Name:
 Multicast DNS: Enabled
 Release DHCP Leases and DNS Registrati...: Disabled
 Primary DNS Server: 10.61.7.16
 Alternate DNS Server 1: 10.61.10.6
 Alternate DNS Server 2: 10.61.10.7
 DNS Connection Timeout: 5
 Append Device Domain: Enabled
 Append Parent Domains: Disabled
 DNS Domain Search List: xeroxqa.com, XEROXQA.COM
 Prefer IPv6 DNS over IPv4: Enabled

Installed Options

PS: Installed

Protocols (cont.)

Bonjour:
 Bonjour Printer Name: Xerox EC8136 Color MFP (9D:A2:3C)

HTTP:
 Enabled
 Port Number: 80
 Force Traffic over Secure Connection (H...): Yes
 Secure HTTP Port Number: 443
 Proxy Server: Manual
 Proxy Server Address: www.mc.xerox.com:8000
 [PP]: Enabled
 Secure IPP Mode: IPP and Secure IPPS
 IPP Network Path: http://10.61.12.190:631

SNMP
 SNMP v1/v2: Enabled
 SNMP v3: Disabled

LPR/LPD:
 Enabled
 Port Number: 515
 PDL Switching: Disabled
 PDL Banner Override: Disabled

Raw IP Printing:
 Enabled
 Port Number 1: 9100
 Bidirectional: Disabled
 End of Job Timeout: 300
 PDL Switching: Disabled

LDAP
 LDAP Server 1 Friendly Name:
 LDAP Server 1 Primary LDAP Address: 0.0.0.0:389
 LDAP Server 1 Alternate LDAP Address: 0.0.0.0:389
 LDAP Server 1 Search Directory Root:
 LDAP Server 1 Secure Connection (LDA...): Disabled
 LDAP Server 1 Validate Server Certificate...: Disabled

SMTP
 SMTP Server: 10.61.23.93:25
 Connect Encryption (TLS): No Encryption
 Validate Server Certificate (TLS):
 Max Message Size (KB): 10240
 Number of Fragments: 1
 Total Job Size (KB): 300000
 Job Splitting Boundary: Page Boundary
 Credentials for Auto E-mails: None
 Credentials for Walkup User: None
 SMTP Authentication Type: Basic Auth with SMTP

POP3
 POP3 Server: 10.61.11.93:110
 POP3 Secure Connection (TLS): Disabled
 E-mail Address: test@tts13.com
 POP3 Validate Server Certificate:
 Receipt of E-mail via POP3: Enabled
 Send Confirm on Request: Enabled
 Incoming E-mail cover sheet: Disabled

NTP:
 Disabled
 Primary Server: 0.0.0.0:123
 Alternate Server: 0.0.0.0:123

SLP:
 Disabled

FTP Client:
 Enabled
 FTP Client Mode: Passive

Web Services on Device:
 Enabled
 WS-Discovery: Enabled
 WS-Discovery Multicast: Enabled
 WS-Print: Enabled
 WS-Scan: Enabled

Web Services
 Copy Submission: Enabled
 Digital Certificate Management and Secur...: Enabled
 Extensible Service Registration: Enabled
 Job Limits: Enabled
 Job Management Extension: Enabled
 Device Configuration: Enabled
 Scan Submission: Enabled
 Scan Workflow Management: Enabled
 Session Data: Enabled
 User Interface Configuration: Enabled
 EIP Proxy Configuration: Enabled
 Xerox Secure Access: Disabled
 EIP SNMP Configuration: Enabled
 Print Submission: Enabled
 Scan Template Mgmt: Enabled
 Mass Storage Access: Enabled
 Card Reader Access: Enabled
 Authentication & Accounting Configur...: Enabled
 Export Audit Log: Enabled
 Trellix Embedded Control: Enabled

Apps

Printing

Banner Sheet: Disabled
 Sys/Start Job: Disabled
 Delete Held Jobs After: 3 Day(s) 0 Hour(s) 0 Minute(s)
 Error Sheets: Enabled
 Paper Substitution: Enabled
 Tray Priority: 1,2,3,4,5
 Default Copies: 1
 Default Job Type: Normal Print
 Default Paper Size: x=210mm, y=297mm
 Default Paper Color: White
 Default 2 Sided Printing: 2 Sided
 Default Output Tray: Main Tray
 Default Output Color: Color
 Default Collated Sets: Enabled
 Default Stapling: No Staple
 Offsetting Between Jobs: Offset Between Jobs
 PostScript: Installed
 Level: 3
 Version: 3021.101
 Image Quality: Standard

PCL
 Version: 6
 Pitch Size: 10.00
 Point Size: 12.00
 Font Name: Courier
 Lines Per Page: 64
 Custom Color Tables: Enabled
 Label: Not Installed

Fax:
 Enabled/Displayed
 Fax Line 1: 3337
 Fax Line 2: 3337

Server Fax:
 Enabled
 Confirmation Sheet: Errors Only
 Delay Start: Disabled
 Repository Protocol: SMB
 Repository Server: 0.0.0.0
 Repository Document Path:

Workflow Scanning:
 Enabled
 Confirmation Sheet: Errors Only
 Default Repository Protocol: SMB
 Default Repository Server: 0.0.0.0
 Default Repository Document Path:
 Default Repository Login Credentials: Device
 Alt1 Repository Protocol: SMB
 Alt1 Repository Server: 0.0.0.0
 Alt1 Repository Document Path:
 Alt1 Repository Login Credentials: Device
 Workflow Pool Protocol: SMB
 Workflow Pool Server: 0.0.0.0
 Workflow Pool Path:

Email:
 Enabled
 Default From Address: test@tts13.com
 Confirmation Sheet: Errors Only
 Auto Send to Self: Disabled
 E-mail Security: Disabled

Scan to Mailbox:
 Enabled
 View Mailboxes by Default: Enabled
 Storage Capacity (MB): 23443 MB
 Storage Used (MB): 1264 MB
 Cleanup of Public Folders: Enabled
 Cleanup of Created Folders: Enabled
 Cleanup Time: Daily

Scan to Home:
 Disabled
 Friendly Name:
 Workflow Name:
 Auto Create Subdir: Disabled
 Append User Name to Path: Disabled
 Auto Create User Name Dir: Disabled

Scan To:
 Enabled
 Disabled
 Cloud Services: Disabled

Print From:
 Enabled
 Saved Jobs for Reprint: Enabled
 Print From USB: Enabled
 Print From MailBox: Disabled
 Cloud Services: Disabled

Accounting

Accounting Mode: None
 Network Accounting: Disabled

Security**Authentication Configuration**

Machine UI Authentication: Locally on the Device
 Home: Unlocked
 Jobs: Unlocked
 Device: Unlocked
 Device Website Authentication: Locally on the Device
 Authorization: Locally on the Device
 Retrieve E-mail from LDAP: Enabled

Authentication Server:

Kerberos: Kerberos
 Kerberos Primary Realm:
 Kerberos Primary Address: 0.0.0.88
 Kerberos Alt 1 Realm:
 Kerberos Alt 1 Address: 0.0.0.88
 SMB NT Domain:
 SMB Alt 1 NT Domain:
 Smartcard Ctl Server: 0.0.0.443
 Smartcard Ctl Domain:
 SmartCard OCSP URL:
 Card Reader Upgrade Policy: Enabled
 Card Reader Firmware Version:

Xerox Secure Access:

Secure Access Server: Disabled
 Secure Access Path: 0.0.0.443

Audit Log:

Enabled

IP Sec:

Disabled

IP Filtering:

Disabled

Security Certificates

Machine Certificate: Signed

Root Certificates Installed: S4

802.1x:

Disabled

Image Overwrite

Immediate: Installed/Enabled

Scheduled: Disabled

Scheduled Frequency:

FIPS 140-3:

Disabled

TLS:

TLS 1.2 and TLS 1.3

TLS Hash: SHA-1, SHA-256 and above

Trellix Embedded Control:

Enhanced Security

Extensible Service Setup

Third Generation Browser: X3G_3 24.23_2.40.5_011_01.00.00

Widget Version: v1.3.17 c8 20140613

Widget Version: v2.5.04 g9 20240123

Control Panel

Available apps can vary based on your printer setup. For details about apps and features, refer to the *User Guide*.

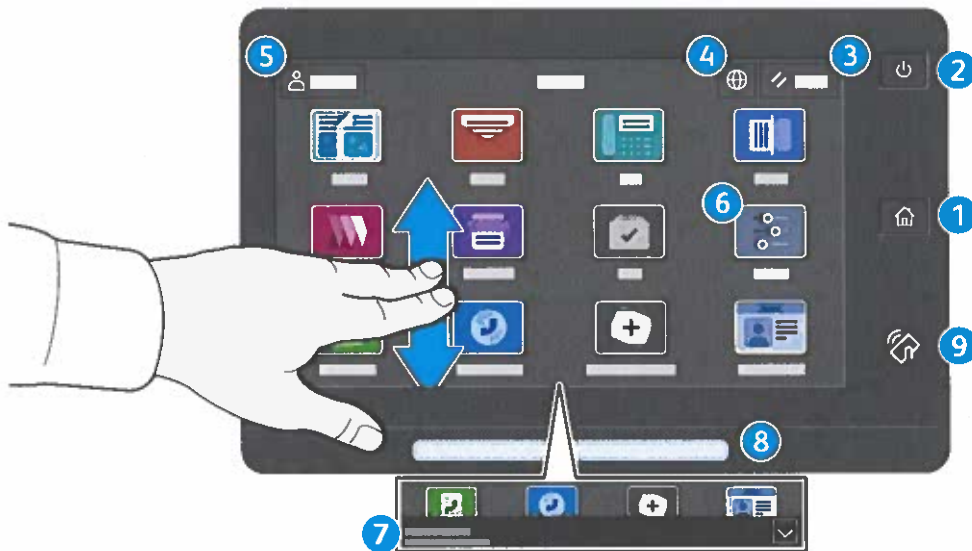

- 1 **Home** returns to the main app screen.
- 2 **Power/Wake** starts the printer or provides options to sleep, restart or power off the printer.
- 3 **Reset** restores settings to their default values in all apps.
- 4 **Language** provides choice of screen languages.
- 5 **Log In** provides special access to tools and settings.
- 6 **Device app** provides access to printer information and settings.
- 7 **Notification banner** shows printer status and warnings. To see all notifications, touch the banner. To close the banner, touch the down arrow.
- 8 **Status LED** indicates printer status. For detailed information, refer to the *User Guide*.
- 9 **NFC Area** allows pairing with a mobile device to print or scan from an app.

Device app

The Device app provides access to supplies status, printer information, and settings. Some menus and settings require log in with the administrator name and password.

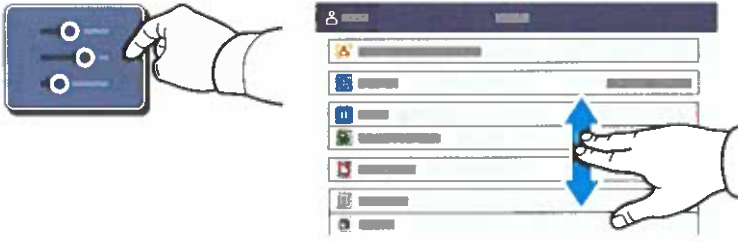

Billing and Usage Information

In the Device features menu, to view basic impression counts, touch **Billing/Usage**. To view detailed usage counts, touch **Usage Counters**. The list provides detailed impression count categories.



Embedded Web Server

The Xerox® Embedded Web Server enables you to access printer configuration details, paper and supplies status, job status, and diagnostic functions over a network. You can also manage fax, email, and address books.

To connect, in a Web browser, type the printer IP address. The network IPv4 address is available on the control panel touch screen. Touch **Device app** > **About**, then scroll down.

For details on using the Embedded Web Server, refer to the *User Guide* located on Xerox.com.

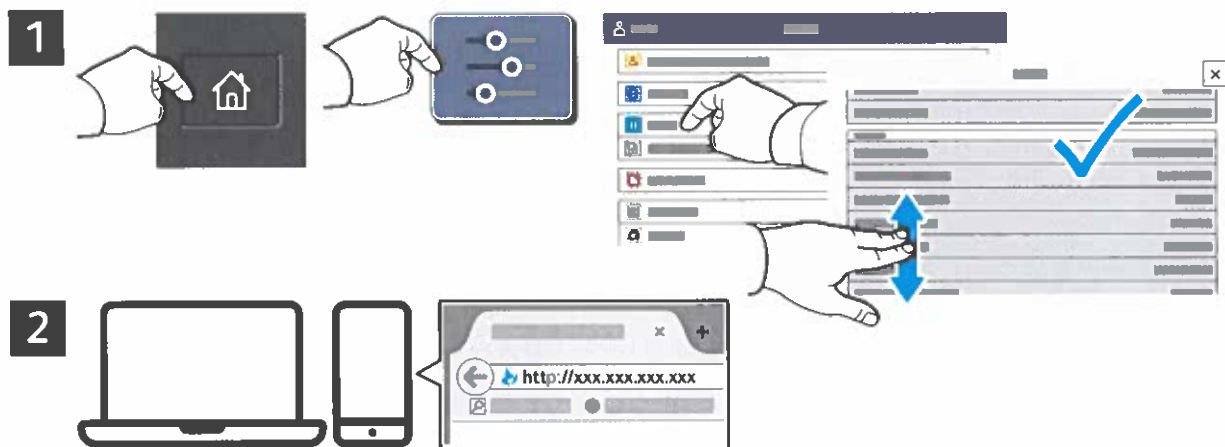

App Gallery

The Xerox App Gallery has a growing collection of productivity apps that you can install on your printer. Find the app on your home screen and create your login directly, or go to www.xerox.com/appgallery to log in and add your device. To simplify app installation, use the same name for your app gallery login credentials that you used for the printer login.

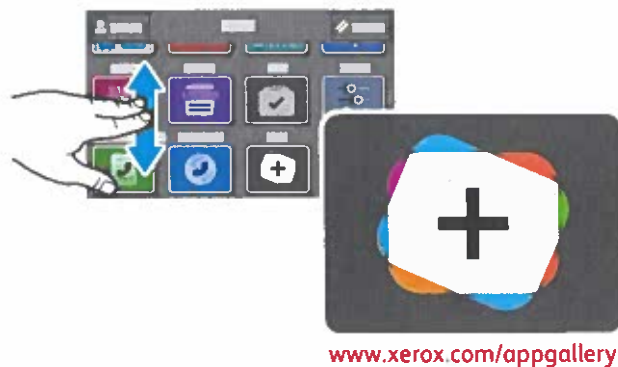

Printer Tour

Optional accessories can be part of your printer setup. For details, refer to the *User Guide*.

Single-Pass Duplex Automatic Document Feeder (DADF)

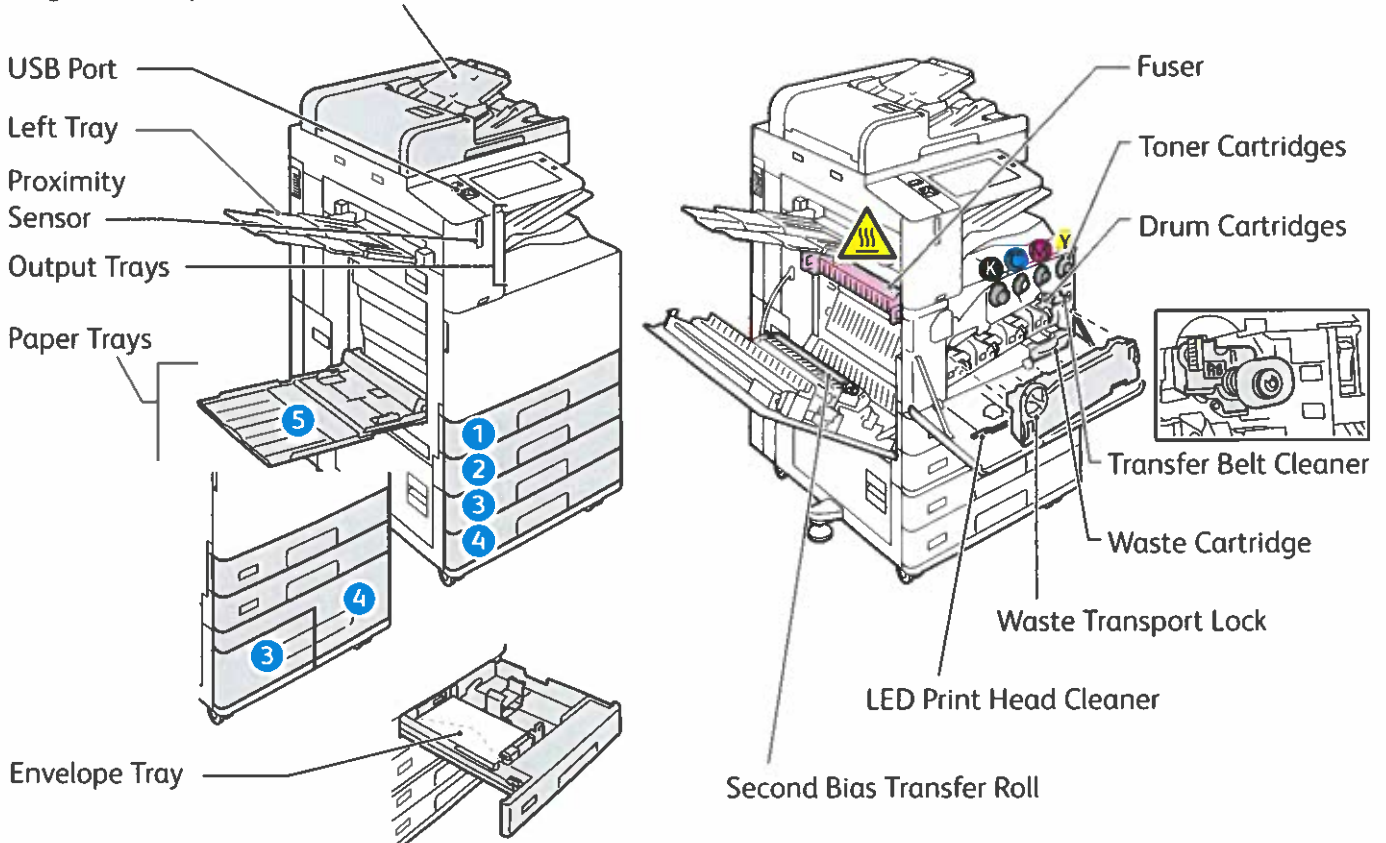

The diagram shows two power switches: (1) the secondary power switch on the control panel, and (2) the main power switch located behind the front cover.

To restart the printer, on the control panel, press the **secondary power switch (1)**.

For full printer power off, press the **secondary power switch (1)**. Behind the front cover, press the **main power switch (2)**.

To select sleep mode, press the **secondary power switch (1)**. At the printer control panel touch screen, touch a selection.

Paper Handling

For a complete list of paper that works with your printer, see the Recommended Media List at:

www.xerox.com/rmlna (U. S. and Canada)

www.xerox.com/rmleu (Europe)

For details about trays and paper, refer to the *User Guide*.

Loading Paper

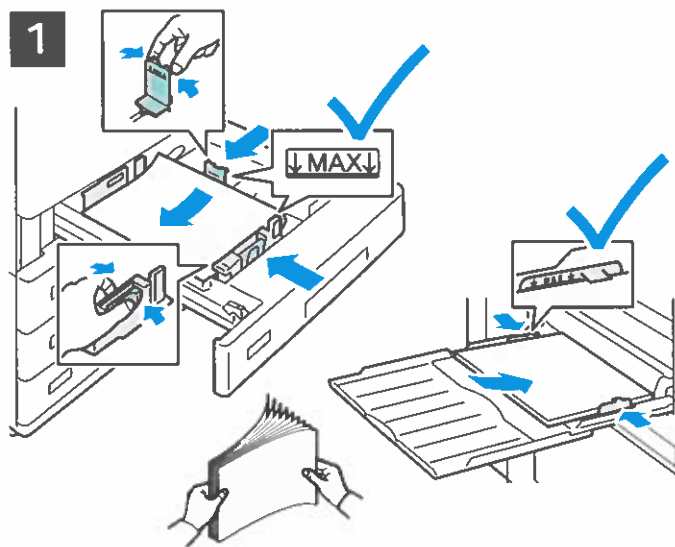

Confirm or change size, type, and color settings if needed.



For the best results, fan the edges of the paper. Adjust the guides to fit the paper size. Do not load paper above the maximum fill line.

When printing, select options in the print driver.

Paper Orientation

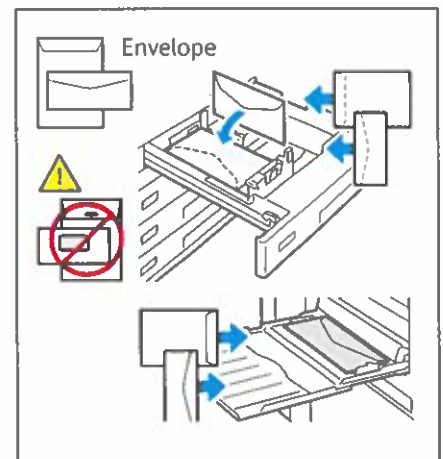
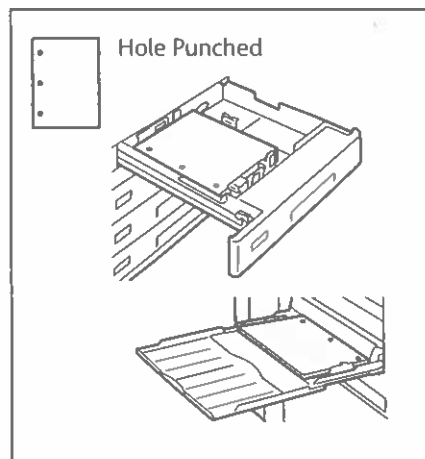
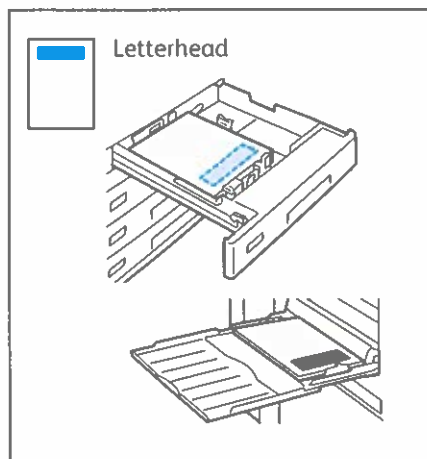

Copying

For details, refer to the *User Guide*.

1

 X: 85–432 mm (3.3–17 in.)
Y: 125–297 mm (4.9–11.7 in.)

 38–128 g/m²
(26 lb. Text–34 lb. Bond)

 ≤130 (80 g/m², 20 lb. Bond)

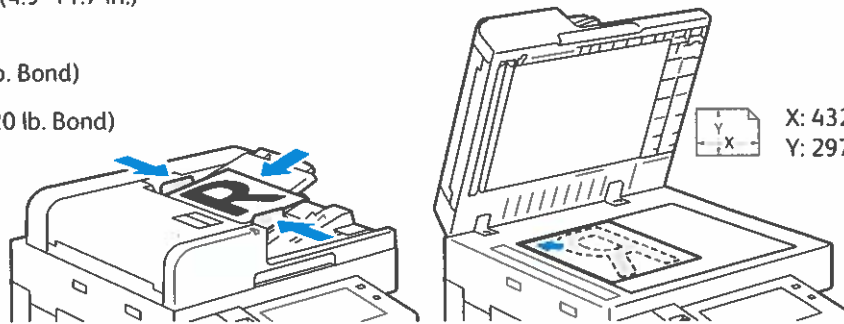

Load the original documents.

2



Touch **Copy**, then and select the number of copies.

3



Select feature settings from the list, then touch **Start**.



Note: Settings from previous users remain onscreen for a short time. To restore the default settings in an app, scroll to the bottom of the feature list and touch **Reset**.

Scanning and Emailing

If the printer is connected to a network, you can select a destination for the scanned image at the printer control panel.

This guide defines techniques to scan documents without preparing special setups:

- Scanning documents to an email address.
- Scanning documents to a saved Favorite, Address Book listing, or USB Flash Drive.
- Scanning documents to the Default Public folder on the printer hard drive, and retrieving them using your Web browser.

For details and more scan setups, refer to the *User Guide*. For details about address book and workflow template setup, refer to the *System Administrator Guide*.

1



X: 85–432 mm (3.3–17 in.)
Y: 125–297 mm (4.9–11.7 in.)



38–128 g/m²
(26 lb. Text–34 lb. Bond)



≤130 (80 g/m², 20 lb. Bond)

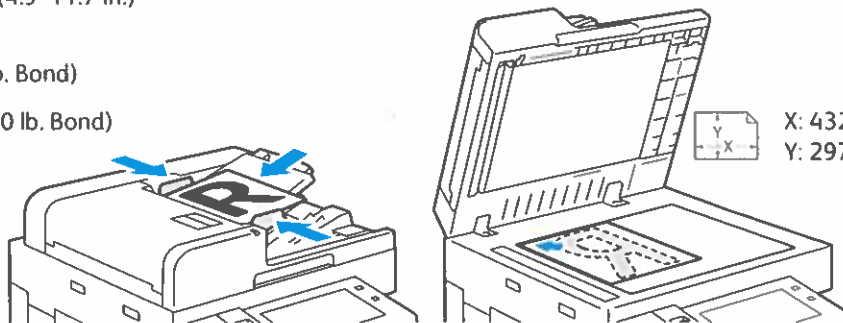

Load the original documents.

2



Press **Home**, then to email the scan, touch **Email**. To scan to the Default Public Folder or a USB Flash Drive, touch **Workflow Scanning**. If your scan destination is stored in the Address Book or saved as a Favorite, touch **Scan To**.

3



For Email, touch **Manual Entry**, type the email address using the touch screen keypad, then touch **Add**. To add more than one email address to the list, touch **Add Recipient**. To type a subject line for the email, touch **Subject**. To select saved email addresses, use the Device Address Book or select from Favorites.



For Workflow Scanning, touch **Default Public Folder**, or insert your USB Flash Drive.

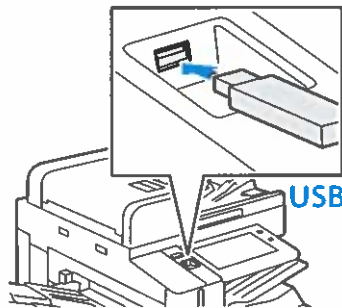

For Scan To, touch a destination type, then enter the appropriate information. To add more than one destination to the list, touch **Add Destination**.

4



Change the settings as needed, then touch **Scan**, or for Email, touch **Send**.

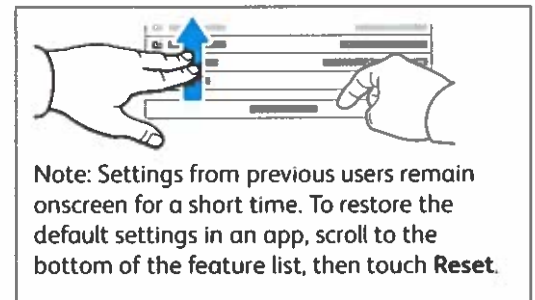

Note: Settings from previous users remain onscreen for a short time. To restore the default settings in an app, scroll to the bottom of the feature list, then touch **Reset**.

Retrieving Scan Files

To download your scanned images from the Default Public Folder on the printer, use the Embedded Web Server. You can set up personal folders and workflow scanning templates in the Embedded Web Server. For details, refer to the *User Guide*.



Note the printer IP address on the touch screen. If the IP Address does not appear in the top of the touch screen, press Home, touch **Device** > **About** then scroll to check the IP Address.

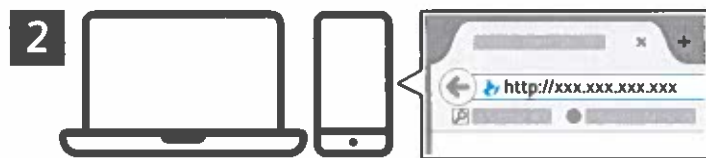

In a Web browser, type the printer IP address, then press **Enter** or **Return**.

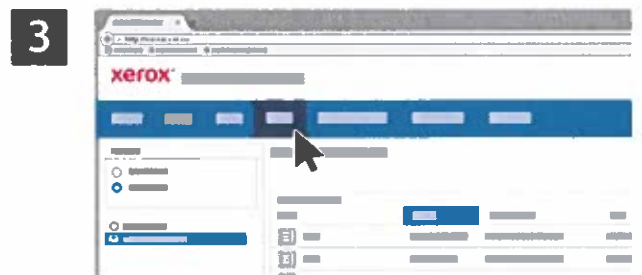

Click the **Scan** tab.



Select the **Default Public Folder**, then find your scan in the list. To download the scan, click **Go**.

 A close-up screenshot of the Xerox web interface showing a list of scan jobs. A callout box points to an 'Update View' button. Another callout box points to a 'Download' button. Below the screenshot, there are four lines of text explaining the actions: 'To refresh the list, click **Update View**.', 'To save the file to your computer, select **Download**.', 'To print the saved file again, select **Reprint**.', and 'To permanently remove the stored job, select **Delete**.', and 'To open a directory, select **Open**.'

Faxing

You can send a fax in one of four ways:

- **Fax** scans the document then sends it directly to a fax machine.
- **Server Fax** scans the document then sends it to a fax server, which transmits the document to a fax machine.
- **Internet Fax** scans the document then emails it to a recipient.
- **LAN Fax** sends the current print job as a fax.

For details, refer to the *User Guide*. For details about LAN Fax, refer to the print driver software. For details about fax setup and advanced settings, refer to the *System Administrator Guide*.

1



X: 85–432 mm (3.3–17 in.)
Y: 125–297 mm (4.9–11.7 in.)



38–128 g/m²
(26 lb. Text–34 lb. Bond)



≤130 (80 g/m², 20 lb. Bond)

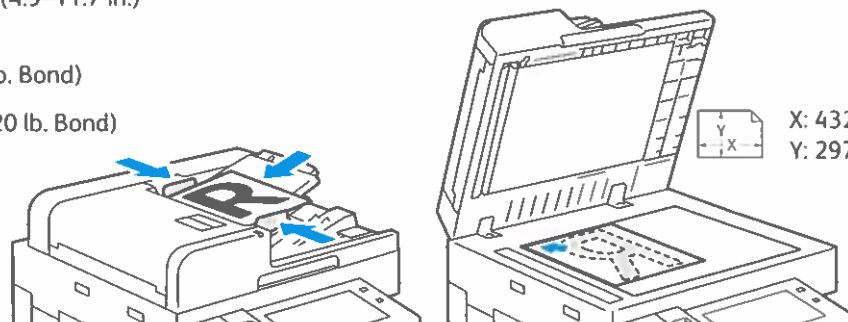

Load the original document.

2



To send the fax to a fax machine, press **Home**, then touch **Fax** or **Server Fax**.

To send the fax as an email attachment, touch **Home**, then touch **Internet Fax**.

3

3.1

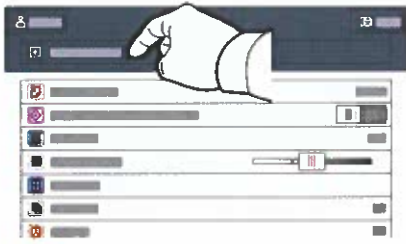

3.2

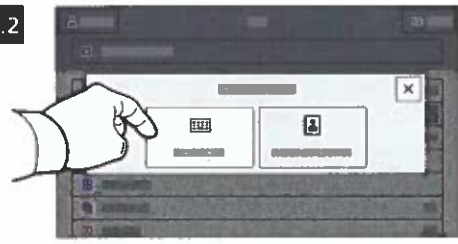

3.3



For fax numbers, touch **Manual Entry**, then enter the fax number using the touch screen alphanumeric keys and special characters. Touch **Add**. To add more fax numbers to the list, touch **Add Recipient**.

For Internet Fax email addresses, touch **Manual Entry**, then enter the email address using the touch screen keypad. Touch **Add**. To add more email addresses to the list, touch **Add Recipient**.

To select saved numbers, use the Device Address Book or Favorites. To select stored fax locations, use the Mailbox or Polling.

4

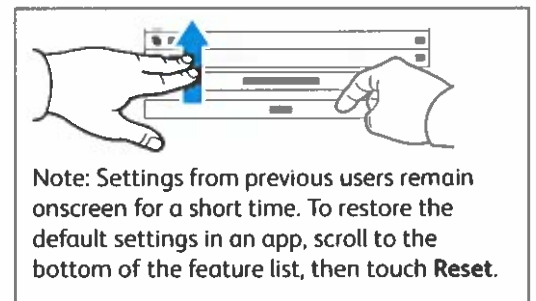

Note: Settings from previous users remain onscreen for a short time. To restore the default settings in an app, scroll to the bottom of the feature list, then touch **Reset**.

Change the settings as needed, then touch **Send**.

Printing from a USB Flash Drive

You can print .pdf, .tiff, .ps, .xps and other files types directly from a USB Flash Drive. For more information, refer to the *User Guide*.

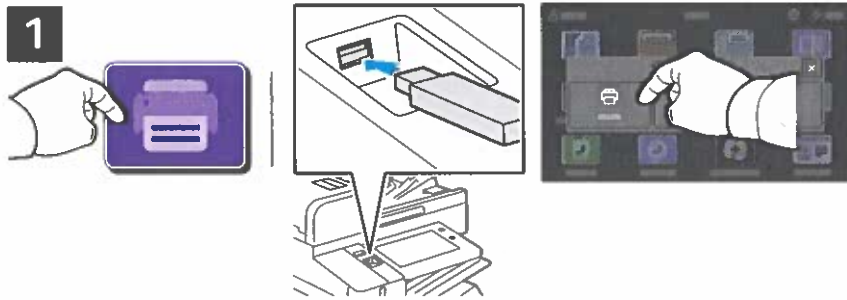

Touch **Print From** or insert your USB Flash Drive, then choose **Print From USB**.

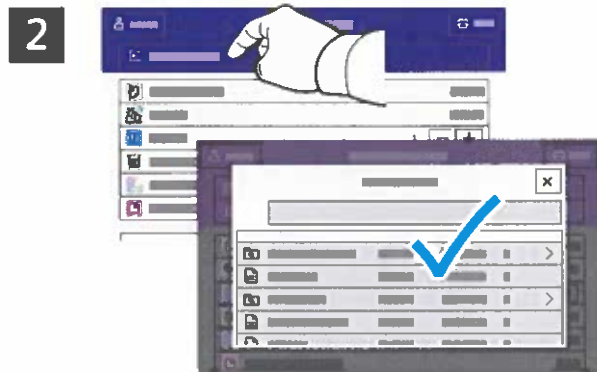

Touch **Add Document**, then navigate to your files and select them.

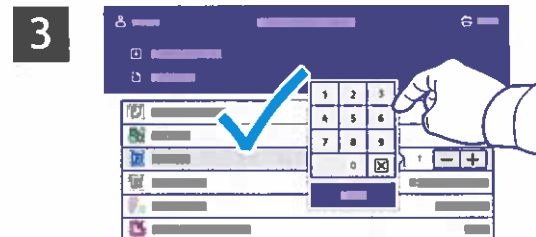

To select the number of copies, touch the plus sign (+) or the minus sign (-). For larger numbers, touch **Quantity** then enter a number.



Select settings as needed, then touch **Print**.

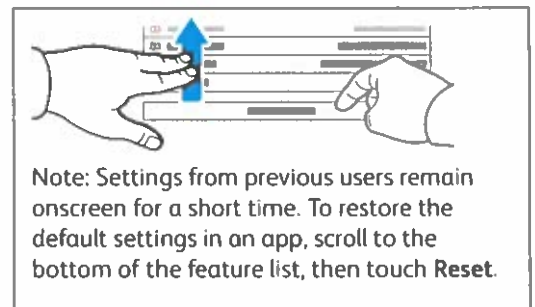

Printing Jobs Stored on the Printer



You can send a print job to save to the printer, then select the job from the printer control panel to print at a later time. Jobs can be saved in the public folder or be password protected. In the Xerox® printer driver, select **Properties** (Windows) or **Xerox Features** (Mac OS), then **Job Type**. Select **Saved Job** or **Secure Print**. For Secure Print, type a passcode. Click **OK** and print the job.

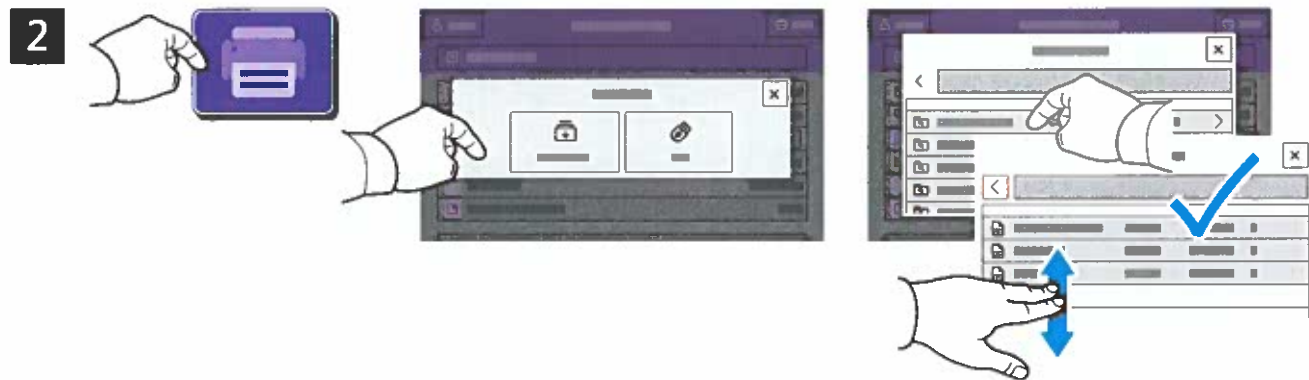

Touch **Print From** then touch **Saved Jobs**. Select the **Default Public Folder** then select your print job.

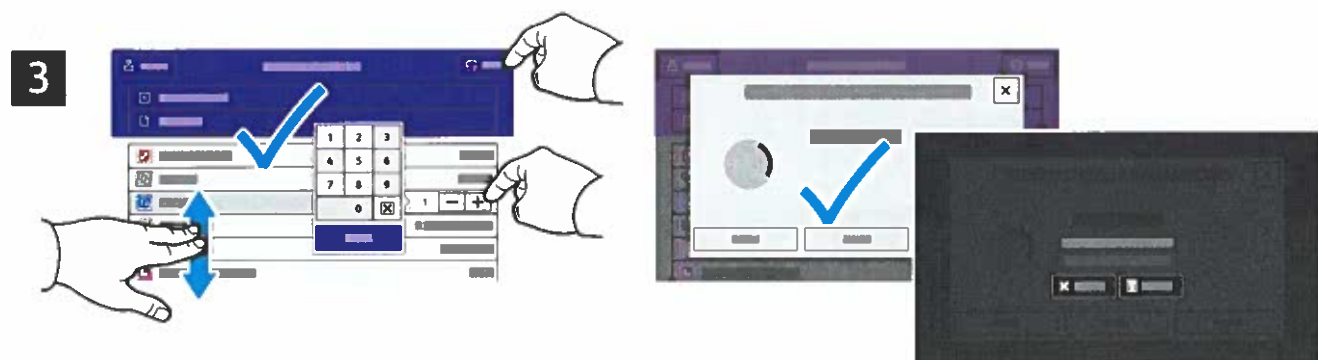

Select settings from the list. To select the number of copies, touch the plus sign (+) or the minus sign (-). For larger numbers, touch **Quantity** then enter a number. Touch **Print**. To delete the job, in the printing screen and confirmation screen, touch **Delete**.

Troubleshooting Print Quality

Your Xerox® EC8100 Series Color Multifunction Printer is designed to produce high-quality color prints consistently. If you observe print-quality problems, use the information on these pages to troubleshoot the problems. For detailed online support information, go to www.xerox.com/office/support.

CAUTION: The Xerox® warranty, Service Agreement, or Total Satisfaction Guarantee does not cover damage caused by using unsupported paper, transparencies, or other specialty media. The Total Satisfaction Guarantee is available in the United States and Canada. Coverage can vary outside of these areas. For details, contact your local representative.

Paper Type

CAUTION: If you change the type of paper in the tray, change the paper type at the control panel to match the paper in the tray. If you fail to change the paper type, it can cause print-quality problems and damage the fuser.

For the best results, only use recommended Xerox® paper and media. Xerox® paper and media are guaranteed to produce excellent results on your Xerox® EC8100 Series Color Multifunction Printer. To order Xerox® paper and media, go to www.xerox.com/office/supplies.

For a complete list of recommended paper for your printer, go to:

- North America: www.xerox.com/rmlna
- Europe: www.xerox.com/rmleu

Solving Print-Quality Problems

Use the following tables to find specific solutions to print-quality problems.

Note: The images that appear represent long-edge feed prints. If you print short-edge feed, the print-quality defects are rotated 90 degrees. The images that appear are for reference only. Not all pages represented are printed.

Solving Print-Quality Problems

Problem

Light Lines or Streaks in One Color

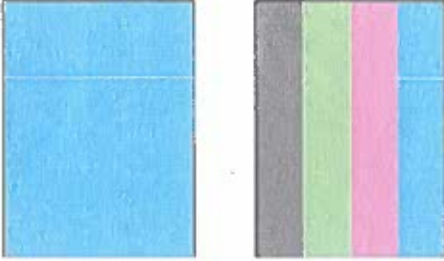

Solution

1. Open the front cover.

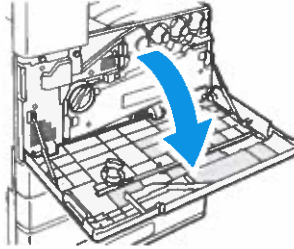

2. To unlock the belt tension lever, on the left side of the printer, rotate the belt tension lever, then open the drum cartridge cover.

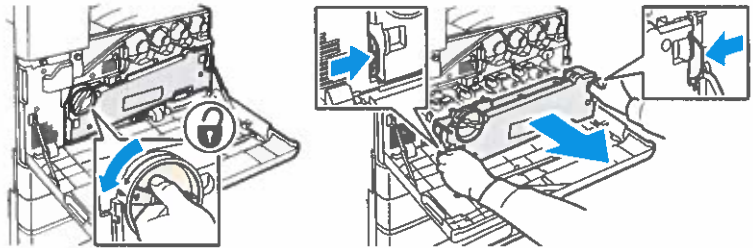

3. Pull out the LED print head cleaner until it stops, then move it all the way in and out two or three times. Repeat this process for all four toner units.

Note: Ensure that you pull the LED print head cleaners out as far as they will go. Push them in as far as they will go. Do not use excessive force.

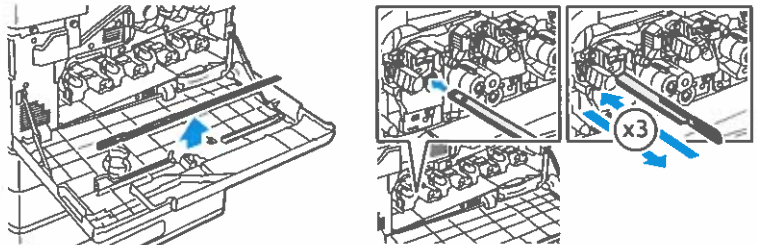



If the problem persists, check if the drum cartridge is causing the problem. To check, switch the suspected drum cartridge with another drum cartridge of a different color. If the problem occurs where you move the suspected drum cartridge, replace the suspected drum cartridge.

Solving Print-Quality Problems (continued)

Problem	Solution
<p data-bbox="108 407 319 436">Incomplete Fusing</p> <p data-bbox="108 443 598 504">Toner appears to be missing from the print, or rubs off easily.</p> 	<ol style="list-style-type: none"><li data-bbox="657 407 1417 465">1. Verify that the paper you are using is the correct type for the printer and is properly loaded. For a complete list of recommended paper for your printer, go to:<ul style="list-style-type: none"><li data-bbox="694 515 1157 544">– North America: www.xerox.com/rmlna<li data-bbox="694 555 1077 584">– Europe: www.xerox.com/rmleu<li data-bbox="657 595 1423 654">2. Verify that the paper type is selected on the control panel and in the print driver.<li data-bbox="657 665 1444 795">3. If the problem persists, do one of the following:<ol style="list-style-type: none"><li data-bbox="694 705 1444 795">a. For dedicated trays, log in as admin, touch Device > Tools > Device Settings > Paper Management > Tray Settings. Select the tray, touch Edit, then change the paper type. Note: To change the size, type, or color of paper in a dedicated tray when the control panel is locked, log in as the system administrator.<li data-bbox="694 878 1396 985">b. For trays that are set to Fully Adjustable:<ul style="list-style-type: none"><li data-bbox="730 913 1396 943">• Trays 1–4 and 6: Open, then close the selected paper tray.<li data-bbox="730 954 1204 983">• Tray 5: Remove, then reinsert the paper.The control panel prompts you to confirm or change the paper type.<li data-bbox="694 1041 1396 1149">c. At the touch screen, touch Type, then do one of the following:<ul style="list-style-type: none"><li data-bbox="730 1077 1316 1106">• Select the correct paper type, then touch Confirm.<li data-bbox="730 1117 1396 1146">• Select the next heavier type of paper, then touch Confirm. <p data-bbox="694 1160 1204 1189">Note: Paper types from lightest to heaviest are:</p> <ul style="list-style-type: none"><li data-bbox="730 1200 1423 1258">• For uncoated paper: Plain, Lightweight Cardstock, Cardstock, and Heavyweight Cardstock.<li data-bbox="730 1270 1364 1328">• For coated paper: Lightweight Glossy Cardstock, Glossy Cardstock, and Heavyweight Glossy Cardstock.

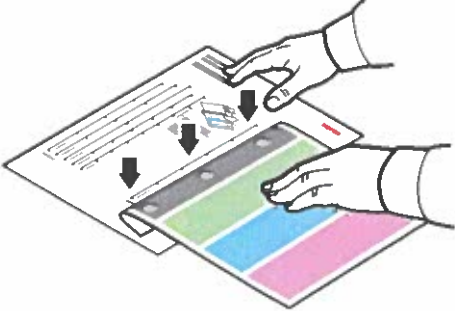

Solving Print-Quality Problems (continued)

Problem	Solution
<p>Repeating Defects Spots or lines appear at regular intervals on the page in the direction that the paper moves through the printer in all colors or in non-printed areas.</p>  <p>Spots or lines appear at regular intervals on the page, in the direction the paper moves through the printer, and in one color only.</p> 	<ol style="list-style-type: none">1. At the control panel, touch Device > Tools > Troubleshooting > Support Pages > Repeating Defects Page > Print. The Repeating Defects Page prints with instructions for identifying defective units.2. To correct the problem, replace items identified on the Repeating Defects Page. 3. If you replaced the the transfer roller, reset the counter:<ol style="list-style-type: none">a. At the control panel, press Log In. Enter system administrator login information, then touch Enter. For details, refer to the <i>System Administrator Guide</i>.b. Touch Device > Tools > Device Settings.c. Scroll, then touch Supplies > Supply Counter Reset.d. Touch Second Bias Transfer Roll.e. Touch Reset Counter.f. To close the pop-up window, touch X, touch admin, then select Logout.

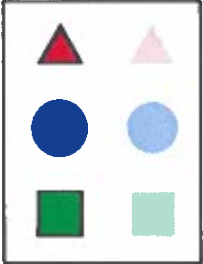
Solving Print-Quality Problems (continued)

Problem	Solution
<p>Offset Image</p> <p>The most common offset is toner that appears to be reprinted on the page and placed about 95 mm (3.75 in.) across the page in the direction that the paper moves through the printer.</p> <p>Note: For a different distance, use the Repeating Defects Page to identify the cause.</p> 	<ol style="list-style-type: none">1. Verify that the paper you are using is the correct paper type for the printer and is properly loaded. For a complete list of recommended paper for your printer, go to:<ul style="list-style-type: none">– North America: www.xerox.com/rmlna– Europe: www.xerox.com/rmleu2. Verify that the paper type is selected on the control panel and in the print driver. Note: To change the size, type, or color of paper in a dedicated tray when the control panel is locked, log in as the system administrator.3. If the problem continues, do one of the following:<ol style="list-style-type: none">a. For dedicated trays, log in as admin, touch Device > Tools > Device Settings > Paper Management > Tray Settings. Select the tray, touch Edit, then change the paper type.b. For trays that are set to Fully Adjustable:<ul style="list-style-type: none">• Trays 1–4 and 6: Open, then close the selected paper tray.• Tray 5: Remove, then reinsert the paper.The control panel prompts you to confirm or change the paper type.c. At the touch screen, touch Type, then do one of the following:<ul style="list-style-type: none">• Select the correct paper type, then touch Confirm.• Select the next heavier paper type, then touch Confirm.Note: Paper types from lightest to heaviest are:<ul style="list-style-type: none">• For uncoated paper: Plain, Lightweight Cardstock, Cardstock, and Heavyweight Cardstock.• For coated paper: Lightweight Glossy Cardstock, Glossy Cardstock, and Heavyweight Glossy Cardstock.d. To identify the cause, use the Repeating Defects Page. For details, refer to the previous page.

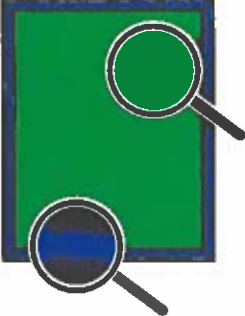
Solving Print-Quality Problems (continued)

Problem	Solution
<p>Heavy Coverage Appears Mottled or Blotchy Blacks Appear Blue</p> 	<ol style="list-style-type: none"> 1. Verify that the paper you are using is the correct type for the printer and is properly loaded. For a complete list of recommended paper for your printer, go to: <ul style="list-style-type: none"> – North America: www.xerox.com/rmlna – Europe: www.xerox.com/rmleu 2. Verify that the paper type is selected on the control panel and in the print driver. <p>If the problem continues, call for service.</p>
<p>Colors Align Incorrectly Color has shifted outside the designated area or is superimposed over another color.</p> 	<p>Open, then close the front door. The printer performs an automatic registration calibration with the next print.</p>
<p>All Colors Too Light or Too Dark Colors appear faded or too dark on print or copy.</p>	<ol style="list-style-type: none"> 1. Verify that the paper you are using is the correct type for the printer and is properly loaded. For a complete list of recommended paper for your printer, go to: <ul style="list-style-type: none"> – North America: www.xerox.com/rmlna – Europe: www.xerox.com/rmleu 2. Verify that the paper type is selected on the control panel and in the print driver. 3. Calibrate the printer colors. The calibration procedure adjusts the printer color balance and lightness level. At the control panel, touch Device > Tools > Troubleshooting > Calibration > Print Calibration or Copy Calibration. Follow the onscreen instructions to run the calibration procedure. <p>Note: For information about changing the Lightness setting in the PostScript print driver for your operating system, refer to the <i>Printing</i> chapter of the <i>User Guide</i>.</p>

Solving Print-Quality Problems (continued)

Problem	Solution
<p data-bbox="108 389 405 416">Lines, Smudges, or Streaks</p> <p data-bbox="108 427 587 486">Dark or light marks appear on the page in all colors and/or in non-printed areas.</p> 	<ol data-bbox="660 389 1445 1294" style="list-style-type: none">1. Verify that the paper you are using is the correct type for the printer and is properly loaded. For a complete list of recommended paper for your printer, go to:<ul data-bbox="695 499 1385 568" style="list-style-type: none">– North America: www.xerox.com/rmlna– Europe: www.xerox.com/rmleu2. Verify that the paper type is selected on the control panel and in the print driver.3. If the problem persists, follow these steps:<ol data-bbox="695 689 1445 891" style="list-style-type: none">a. At the control panel, touch Device > Information Pages > Troubleshooting Print Quality Page > Print. The Repeating Defects Page prints with instructions for identifying defective units.b. To correct the problem, replace the items identified on the Repeating Defects Page.4. If the problem continues, replace the transfer belt cleaner. If you replace the transfer belt cleaner, reset the counter:<ol data-bbox="695 976 1445 1294" style="list-style-type: none">a. At the control panel, press Log In. Enter system administrator login information, then touch Done. For details, refer to the <i>System Administrator Guide</i>.b. Touch Device > Tools > Device Settings.c. Scroll, then touch Supplies > Supply Counter Reset.d. Touch Transfer Belt Cleaner.e. Touch Confirm Reset.f. To close the pop-up window, touch X, touch admin, then select Logout.

Solving Print-Quality Problems (continued)

Problem	Solution
<p>Poor Transparency Print Quality Print-quality defects are occurring on transparency film:</p> <ul style="list-style-type: none"> • Light or dark spots • Smeared toner • Light bands on print 	<p>Use only Xerox® Transparencies.</p> <p>CAUTION: Using non-Xerox® transparencies can cause print-quality problems or damage to the fuser. Damage caused by using unsupported media is not covered by the Xerox® Warranty, Service Agreement, or Total Satisfaction Guarantee.</p>
<p>Grays are Not Neutral The grays on the printed page are not neutral; they contain color tints.</p>	<p>Calibrate the printer colors. The calibration process adjusts the printer color balance.</p> <ol style="list-style-type: none"> 1. At the control panel, touch Device > Tools > Troubleshooting > Calibration > Print Calibration. 2. Follow the onscreen instructions to run the Print Calibration procedure.
<p>Colors Vary Between Computers The colors printed from one computer do not match the colors printed from a different computer.</p>	<ol style="list-style-type: none"> 1. Confirm that the print driver settings for Print Quality, Color Correction, and Color By Words are identical on both computers. 2. Adjust the settings as needed. <p>Note: Print driver settings override the settings that are made at the printer control panel.</p>
<p>Colors Do Not Match The color produced by the printer is different from the color that it must match.</p>	<p>For more information about color matching, go to the Online Support Assistant at www.xerox.com/office/support.</p>
<p>Printed Colors Do Not Match Monitor Colors The color produced by the printer looks different from the color that appears on the computer monitor.</p>	<p>To view information about color matching between the monitor and the printed document, go to the Online Support Assistant at www.xerox.com/office/support.</p>

Print-Quality Settings

The Print-Quality mode and Color Corrections options directly control the quality of your prints. You can change these settings in the print driver. Select the setting that is best suited for your print job.

Print-Quality Mode

- **Enhanced** mode is the general-purpose mode for crisp, bright color prints. Enhanced mode balances speed with quality.
- **High Resolution** mode is a high-quality mode that creates fine lines and detail. High Resolution mode is recommended for vibrant, saturated color prints. High Resolution mode balances quality over speed.
- **Toner Saver** mode reduces the amount of toner used for print jobs and is useful for draft-quality output. Print quality is slightly lower than using Standard mode.

Color Corrections

Color corrections are available on the Image Options tab in the print driver. The Preview window appears on the right side of the Image Options tab. When the Preview check box is selected, color correction appear in the Preview window. Selecting and clearing the Preview check box allows you to compare the corrected image to the uncorrected image.

To adjust the color characteristics of your print job, select the Color Correction tab, then select options as needed.

- **Xerox Black and White Conversion** converts the colors to grayscale, producing a black and white print job. This setting is useful for creating black and white master documents for photocopying or faxing.
- **Color Correction** provides options to match the printer colors as closely as possible to colors on other devices, such as your computer screen or a printing press.
 - **Automatic** applies the best color correction to each graphic element of the document: text, artwork, and photographs.
 - **Simulate LCD Display** approximates the print job color to the colors on a LCD computer monitor.
 - **sRGB Display** approximates the print job color to an RGB (red, green, blue) display.
 - **None** removes all color correction. This option is the best choice when working with color specified within your application or operating system.
- **Xerox Automatic Color** applies the best color correction to each graphic element of the document, including text, artwork, and photographs.
- **Custom Automatic Color** provides more options for customizing colors in your print job. Use one selection to adjust the color of the text and graphics. Use the other selection to adjust the color correction applied to images. You can apply a wide range of color options to each element to simulate the outputs of different color devices.

To adjust colors using descriptive phrases, select the **Color By Words** tab. From the menus, select the phrases to build a sentence that describes the color adjustment that you want. You can build more than one sentence for the print job, affecting one color or an entire range of colors.

To change settings for each individual color parameter, select the **Color Adjustments** tab, then adjust the sliders. The sliders allow you to select a continuous range of adjustment for each of the following:

- Lightness
- Contrast
- Saturation
- Cyan to Red
- Magenta to Green
- Yellow to Blue

For more information on color matching and ICC profiles, go to www.xerox.com/office/support.

Supplies Usage

Supplies ordering information is located at www.xerox.com/office/supplies

Consumables

1 Toner Cartridges



Black

Date Installed: May 6, 2024
 Reorder: 006R01742
 Estimated Pages Remaining: 23000
 (Based upon this toner cartridge's average coverage: 2%)

Life Remaining: 100%
 50%
 0%

Cyan

Date Installed: Jan 4, 2023
 Reorder: 006R01743
 Estimated Pages Remaining: 18500
 (Based upon this toner cartridge's average coverage: 1%)

Life Remaining: 100%
 50%
 0%

Magenta

Date Installed: Jan 4, 2023
 Reorder: 006R01744
 Estimated Pages Remaining: 19000
 (Based upon this toner cartridge's average coverage: 2%)

Life Remaining: 100%
 50%
 0%

Yellow

Date Installed: Jan 4, 2023
 Reorder: 006R01745
 Estimated Pages Remaining: 19000
 (Based upon this toner cartridge's average coverage: 1%)

Life Remaining: 100%
 50%
 0%

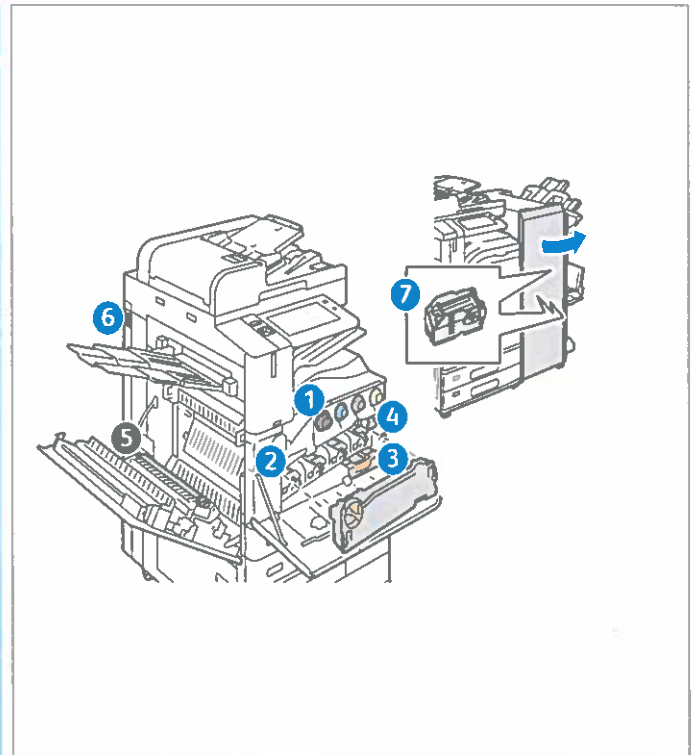

7 Staple Refill



Reorder: 008R12941

OK

Routine Maintenance Items

2 Drum Cartridge



Black (R1)

Date Installed: Oct 9, 2020
 Reorder: 013R00681
 Estimated Pages Remaining: 198000
 (Based on average printer job size: 1 Pages)

Life Remaining: 100%
 50%
 0%

Cyan (R2)

Date Installed: Oct 9, 2020
 Reorder: 013R00681
 Estimated Pages Remaining: 183000
 (Based on average printer job size: 1 Pages)

Life Remaining: 100%
 50%
 0%

Magenta (R3)

Date Installed: Oct 9, 2020
 Reorder: 013R00681
 Estimated Pages Remaining: 183000
 (Based on average printer job size: 1 Pages)

Life Remaining: 100%
 50%
 0%

Yellow (R4)

Date Installed: Oct 9, 2020
 Reorder: 013R00681
 Estimated Pages Remaining: 183000
 (Based on average printer job size: 1 Pages)

Life Remaining: 100%
 50%
 0%

3 Waste Container



Date Installed: Jan 14, 2025
 Reorder: 008R08101

OK

4 Transfer Belt Cleaner



Date Installed: Jan 14, 2025
 Reorder: 001R00623
 Estimated Pages Remaining: 158500

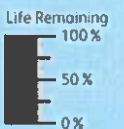

5 Second Bias Transfer Roller



Date Installed: Apr 4, 2025
 Reorder: 008R08103
 Estimated Pages Remaining: 359500



Save Big With Our Spring Sale

BOOST YOUR FLOWER POWER

April showers bring May flowers—so get yours blooming today with 20% off perennials and annuals, now through June 1.



GET DIGGING...

... and weeding and clipping with new garden tools and accessories. We've got great deals on super-sharp shears, shiny spades and shovels, and gloves and clogs to boot. But why stop there? Don't forget to visit our showroom of garden accents featuring bird baths, windchimes, gazing balls, even benches. You won't want to go back indoors!



PLANT FOR WINGED WILDLIFE

Did you know that certain plants attract hummingbirds, butterflies, bluebirds and other winged species?

Talk to our experts about how to create a haven for these delicate beauties. You'll be amazed by the colorful new visitors who will come to sample the pollen and alight on soft flower petals.

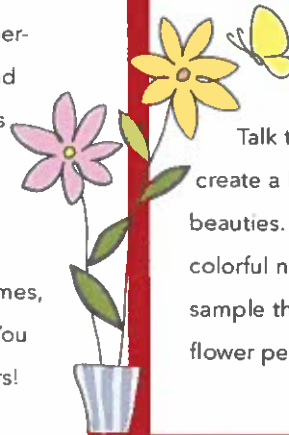

NEWSLETTER SIGN-UP

Sign up today for gardening tips and member discounts delivered to your email.



ALPINE RIDGE
GARDEN CENTERS

info@alpinegardencenter.com

THE ALPINE RIDGE APPROACH TO GARDENING

We're about sustainable gardening, embracing growth without the use of chemicals. Our organic compost replenishes the soil with natural nutrients. We have plants that will help keep pesky insects away, without the need for pesticides. Even our containers are made of recycled paper products that will nurture your plants. It's our pledge to keep your gardens, lawns and all who visit them free from pollutants and full of beauty.

xerox™

Printed on a Xerox® EC8100 Series Color Multifunction Printer. © 2026 Xerox Corporation. All rights reserved. Xerox® is a trademark of Xerox Corporation in the United States and/or other countries. TSK-6795 BR41268 EC8PS-04

Billing Summary

System Information

Machine Name: Xerox EC8136 Color MFP (9D:A2:3C)
 Machine Serial Number: MQ5010507
 Power On Impressions: 2

Software Versions
 Device Software: 122.043.005.09800
 Patch Version: None
 Network Controller: 122.043.09800
 UI Panel Firmware: 003.004.00000
 Marking Engine: 030.045.000
 Document Feeder: 023.026.000
 Finisher: 006.003.000
 Fax: 003.021.015
 Scanner: 016.024.013

Billing Meters

Fax

Embedded Fax Images Sent: 1
 Embedded Fax Impressions: 57

Copy

Black Copied Impressions: 78
 Color Copied Impressions: 20

Print

Black Printed Impressions: 150
 Color Printed Impressions: 723

Scan

Network Scanning Images Sent: 292
 E-mail Images Sent: 21

Plain Paper: 627

Device Totals

Black Impressions: 313
 Color Impressions: 743
 Total Impressions: 1056

