

## Scanning and Emailing

If the printer is connected to a network, you can select a destination for the scanned image at the printer control panel.

This guide defines techniques to scan documents without preparing special setups:

- Scanning documents to an email address.
- Scanning documents to a saved Favorite, Address Book listing, or USB Flash Drive.
- Scanning documents to the Default Public folder on the printer hard drive, and retrieving them using your Web browser.

For details and more scan setups, refer to the *User Guide*. For details about address book and workflow template setup, refer to the *System Administrator Guide*.

1

 X: 85–432 mm (3.3–17 in.)  
Y: 125–297 mm (4.9–11.7 in.)

 38–128 g/m<sup>2</sup>  
(26 lb. Text–34 lb. Bond)

 ≤130 (80 g/m<sup>2</sup>, 20 lb. Bond)  
C8270: ≤250

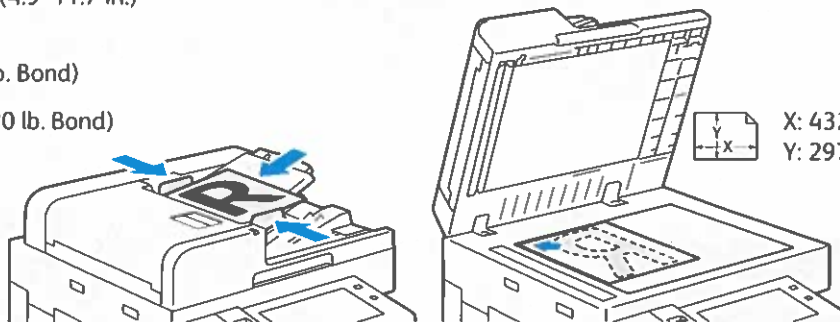

 X: 432 mm (17 in.)  
Y: 297 mm (11.7 in.)

Load the original documents.

2



Press **Home**, then to email the scan, touch **Email**. To scan to the Default Public Folder or a USB Flash Drive, touch **Workflow Scanning**. If your scan destination is stored in the Address Book or saved as a Favorite, touch **Scan To**.

3



For Email, touch **Manual Entry**, type the email address using the touch screen keypad, then touch **Add**. To add more than one email address to the list, touch **Add Recipient**. To type a subject line for the email, touch **Subject**. To select saved email addresses, use the Device Address Book or select from Favorites.



For Workflow Scanning, touch **Default Public Folder**, or insert your USB Flash Drive.

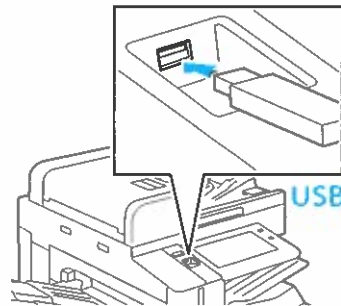

For Scan To, touch a destination type, then enter the appropriate information. To add more than one destination to the list, touch **Add Destination**.

4

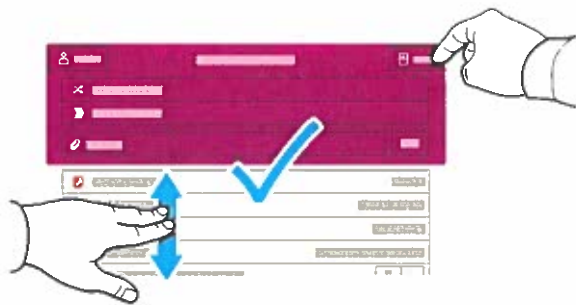

Change the settings as needed, then touch **Scan**, or for Email, touch **Send**.

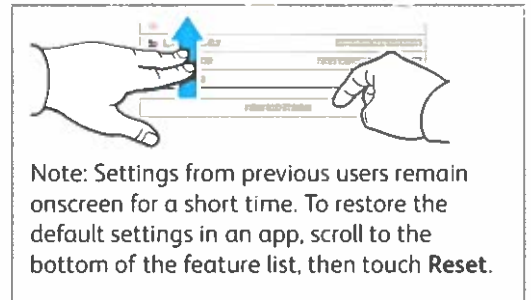

Note: Settings from previous users remain onscreen for a short time. To restore the default settings in an app, scroll to the bottom of the feature list, then touch **Reset**.