

# Troubleshooting Print Quality

Your Xerox® AltaLink® C8230/C8235/C8245/C8255/C8270 Color Multifunction Printer is designed to produce high-quality color prints consistently. If you observe print-quality problems, use the information on these pages to troubleshoot the problems. For detailed online support information, go to [www.xerox.com/office/support](http://www.xerox.com/office/support).

**CAUTION:** The Xerox® warranty, Service Agreement, or Total Satisfaction Guarantee does not cover damage caused by using unsupported paper, transparencies, or other specialty media. The Total Satisfaction Guarantee is available in the United States and Canada. Coverage can vary outside of these areas. For details, contact your local representative.

## Paper Type

**CAUTION:** If you change the type of paper in the tray, change the paper type at the control panel to match the paper in the tray. If you fail to change the paper type, it can cause print-quality problems and damage the fuser.

For the best results, only use recommended Xerox® paper and media. Xerox® paper and media are guaranteed to produce excellent results on your Xerox® AltaLink® C8230/C8235/C8245/C8255/C8270 Color Multifunction Printer. To order Xerox® paper and media, go to [www.xerox.com/office/supplies](http://www.xerox.com/office/supplies).

For a complete list of recommended paper for your printer, go to:

- North America: [www.xerox.com/rmlna](http://www.xerox.com/rmlna)
- Europe: [www.xerox.com/rmleu](http://www.xerox.com/rmleu)

## Solving Print-Quality Problems

Use the following tables to find specific solutions to print-quality problems.

**Note:** The images that appear represent long-edge feed prints. If you print short-edge feed, the print-quality defects are rotated 90 degrees. The images that appear are for reference only. Not all pages represented are printed.

## Solving Print-Quality Problems

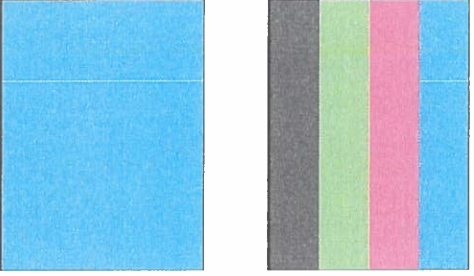
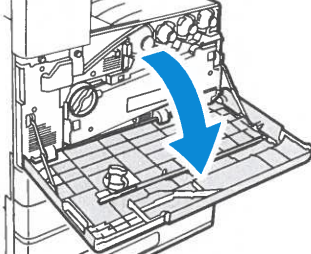
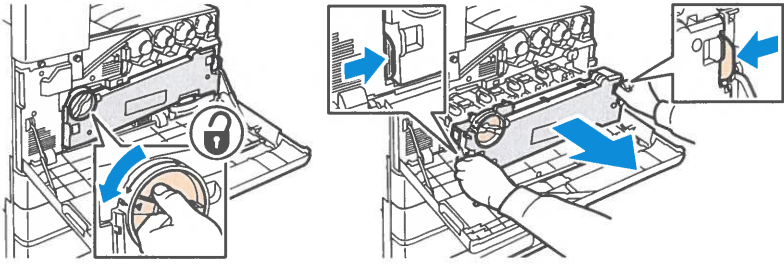
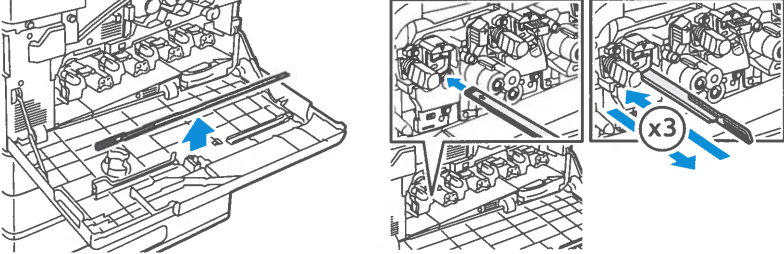
Problem	Solution
<p data-bbox="94 220 495 247"><b>Light Lines or Streaks in One Color</b></p> 	<p data-bbox="657 220 933 247">1. Open the front cover.</p>  <p data-bbox="657 535 1494 598">2. To unlock the belt tension lever, on the left side of the printer, rotate the belt tension lever, then open the drum cartridge cover.</p>  <p data-bbox="657 892 1485 976">3. Pull out the LED print head cleaner until it stops, then move it all the way in and out two or three times. Repeat this process for all four toner units.</p> <p data-bbox="698 997 1461 1081"><b>Note:</b> Ensure that you pull the LED print head cleaners out as far as they will go. Push them in as far as they will go. Do not use excessive force.</p>  <p data-bbox="657 1396 1494 1522">If the problem persists, check if the drum cartridge is causing the problem. To check, switch the suspected drum cartridge with another drum cartridge of a different color. If the problem occurs where you move the suspected drum cartridge, replace the suspected drum cartridge.</p>

## Solving Print-Quality Problems (continued)

Problem	Solution
<p data-bbox="94 233 316 262"><b>Incomplete Fusing</b></p> <p data-bbox="94 275 607 333">Toner appears to be missing from the print, or rubs off easily.</p> 	<ol style="list-style-type: none"><li data-bbox="667 233 1463 294">1. Verify that the paper you are using is the correct type for the printer and is properly loaded. For a complete list of recommended paper for your printer, go to:<ul style="list-style-type: none"><li data-bbox="704 348 1187 378">– North America: <a href="http://www.xerox.com/rmlna">www.xerox.com/rmlna</a></li><li data-bbox="704 390 1101 420">– Europe: <a href="http://www.xerox.com/rmleu">www.xerox.com/rmleu</a></li></ul></li><li data-bbox="667 432 1463 493">2. Verify that the paper type is selected on the control panel and in the print driver.</li><li data-bbox="667 506 1463 640">3. If the problem persists, do one of the following:<ol style="list-style-type: none"><li data-bbox="704 548 1463 640">a. For dedicated trays, log in as admin, touch <b>Device &gt; Tools &gt; Device Settings &gt; Paper Management &gt; Tray Settings</b>. Select the tray, touch <b>Edit</b>, then change the paper type. <b>Note:</b> To change the size, type, or color of paper in a dedicated tray when the control panel is locked, log in as the system administrator.</li><li data-bbox="704 726 1463 840">b. For trays that are set to Fully Adjustable:<ul style="list-style-type: none"><li data-bbox="742 768 1430 798">• Trays 1–4 and 6: Open, then close the selected paper tray.</li><li data-bbox="742 810 1227 840">• Tray 5: Remove, then reinsert the paper.</li></ul>The control panel prompts you to confirm or change the paper type.</li><li data-bbox="704 894 1463 1008">c. At the touch screen, touch <b>Type</b>, then do one of the following:<ul style="list-style-type: none"><li data-bbox="742 936 1344 966">• Select the correct paper type, then touch <b>Confirm</b>.</li><li data-bbox="742 978 1435 1008">• Select the next heavier type of paper, then touch <b>Confirm</b>.</li></ul></li></ol></li></ol> <p data-bbox="704 1020 1224 1050"><b>Note:</b> Paper types from lightest to heaviest are:</p> <ul style="list-style-type: none"><li data-bbox="742 1062 1458 1123">• For uncoated paper: Plain, Lightweight Cardstock, Cardstock, and Heavyweight Cardstock.</li><li data-bbox="742 1136 1398 1197">• For coated paper: Lightweight Glossy Cardstock, Glossy Cardstock, and Heavyweight Glossy Cardstock.</li></ul>

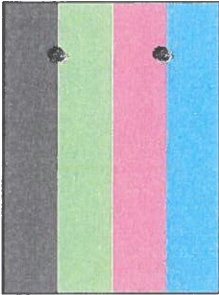
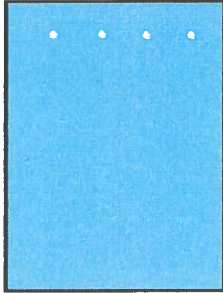
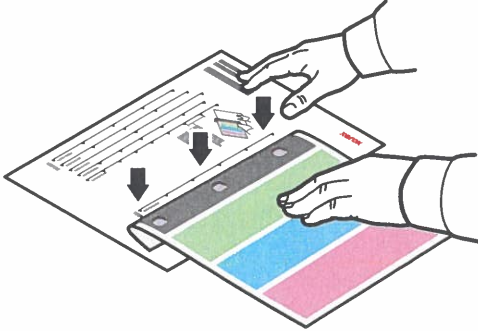

## Solving Print-Quality Problems (continued)

Problem	Solution
<p><b>Repeating Defects</b></p> <p>Spots or lines appear at regular intervals on the page in the direction that the paper moves through the printer in all colors or in non-printed areas.</p>  <p>Spots or lines appear at regular intervals on the page, in the direction the paper moves through the printer, and in one color only.</p> 	<ol style="list-style-type: none"><li>1. At the control panel, touch <b>Device &gt; Tools &gt; Troubleshooting &gt; Support Pages &gt; Repeating Defects Page &gt; Print</b>. The Repeating Defects Page prints with instructions for identifying defective units.</li><li>2. To correct the problem, replace items identified on the Repeating Defects Page. </li><li>3. If you replaced the the transfer roller, reset the counter:<ol style="list-style-type: none"><li>a. At the control panel, press <b>Log In</b>. Enter system administrator login information, then touch <b>Enter</b>. For details, refer to the <i>System Administrator Guide</i>.</li><li>b. Touch <b>Device &gt; Tools &gt; Device Settings</b>.</li><li>c. Scroll, then touch <b>Supplies &gt; Supply Counter Reset</b>.</li><li>d. Touch <b>Second Bias Transfer Roll</b>.</li><li>e. Touch <b>Reset Counter</b>.</li><li>f. To close the pop-up window, touch <b>X</b>, touch <b>admin</b>, then select <b>Logout</b>.</li></ol></li></ol>

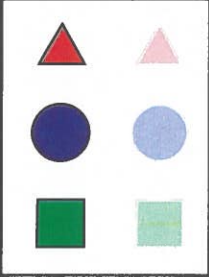
## Solving Print-Quality Problems (continued)

Problem	Solution
<p><b>Offset Image</b></p> <p>The most common offset is toner that appears to be reprinted on the page and placed about 95 mm (3.75 in.) across the page in the direction that the paper moves through the printer.</p> <p><b>Note:</b> For a different distance, use the Repeating Defects Page to identify the cause.</p> 	<ol style="list-style-type: none"><li>1. Verify that the paper you are using is the correct paper type for the printer and is properly loaded. For a complete list of recommended paper for your printer, go to:<ul style="list-style-type: none"><li>– North America: <a href="http://www.xerox.com/rmlna">www.xerox.com/rmlna</a></li><li>– Europe: <a href="http://www.xerox.com/rmleu">www.xerox.com/rmleu</a></li></ul></li><li>2. Verify that the paper type is selected on the control panel and in the print driver. <b>Note:</b> To change the size, type, or color of paper in a dedicated tray when the control panel is locked, log in as the system administrator.</li><li>3. If the problem continues, do one of the following:<ol style="list-style-type: none"><li>a. For dedicated trays, log in as admin, touch <b>Device &gt; Tools &gt; Device Settings &gt; Paper Management &gt; Tray Settings</b>. Select the tray, touch <b>Edit</b>, then change the paper type.</li><li>b. For trays that are set to Fully Adjustable:<ul style="list-style-type: none"><li>• Trays 1–4 and 6: Open, then close the selected paper tray.</li><li>• Tray 5: Remove, then reinsert the paper.</li></ul>The control panel prompts you to confirm or change the paper type.</li><li>c. At the touch screen, touch <b>Type</b>, then do one of the following:<ul style="list-style-type: none"><li>• Select the correct paper type, then touch <b>Confirm</b>.</li><li>• Select the next heavier paper type, then touch <b>Confirm</b>.</li></ul><b>Note:</b> Paper types from lightest to heaviest are:<ul style="list-style-type: none"><li>• For uncoated paper: Plain, Lightweight Cardstock, Cardstock, and Heavyweight Cardstock.</li><li>• For coated paper: Lightweight Glossy Cardstock, Glossy Cardstock, and Heavyweight Glossy Cardstock.</li></ul></li><li>d. To identify the cause, use the Repeating Defects Page. For details, refer to the previous page.</li></ol></li></ol>

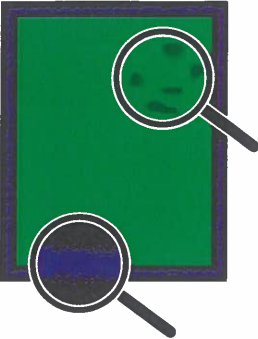
## Solving Print-Quality Problems (continued)

Problem	Solution
<p><b>Heavy Coverage Appears Mottled or Blotchy</b> <b>Blacks Appear Blue</b></p> 	<ol style="list-style-type: none"><li>1. Verify that the paper you are using is the correct type for the printer and is properly loaded. For a complete list of recommended paper for your printer, go to:<ul style="list-style-type: none"><li>– North America: <a href="http://www.xerox.com/rmlna">www.xerox.com/rmlna</a></li><li>– Europe: <a href="http://www.xerox.com/rmleu">www.xerox.com/rmleu</a></li></ul></li><li>2. Verify that the paper type is selected on the control panel and in the print driver.</li></ol> <p>If the problem continues, call for service.</p>
<p><b>Colors Align Incorrectly</b> Color has shifted outside the designated area or is superimposed over another color.</p> 	<p>Open, then close the front door. The printer performs an automatic registration calibration with the next print.</p>
<p><b>All Colors Too Light or Too Dark</b> Colors appear faded or too dark on print or copy.</p>	<ol style="list-style-type: none"><li>1. Verify that the paper you are using is the correct type for the printer and is properly loaded. For a complete list of recommended paper for your printer, go to:<ul style="list-style-type: none"><li>– North America: <a href="http://www.xerox.com/rmlna">www.xerox.com/rmlna</a></li><li>– Europe: <a href="http://www.xerox.com/rmleu">www.xerox.com/rmleu</a></li></ul></li><li>2. Verify that the paper type is selected on the control panel and in the print driver.</li><li>3. Calibrate the printer colors. The calibration procedure adjusts the printer color balance and lightness level. At the control panel, touch <b>Device &gt; Tools &gt; Troubleshooting &gt; Calibration &gt; Print Calibration</b> or <b>Copy Calibration</b>. Follow the onscreen instructions to run the calibration procedure.</li></ol> <p><b>Note:</b> For information about changing the Lightness setting in the PostScript print driver for your operating system, refer to the <i>Printing</i> chapter of the <i>User Guide</i>.</p>

## Solving Print-Quality Problems (continued)

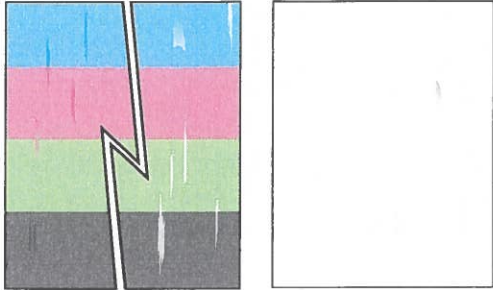
Problem	Solution
<p data-bbox="94 216 407 247"><b>Lines, Smudges, or Streaks</b></p> <p data-bbox="94 258 594 321">Dark or light marks appear on the page in all colors and/or in non-printed areas.</p> 	<ol data-bbox="667 216 1487 1171" style="list-style-type: none"><li>1. Verify that the paper you are using is the correct type for the printer and is properly loaded. For a complete list of recommended paper for your printer, go to:<ul data-bbox="708 331 1425 405" style="list-style-type: none"><li>– North America: <a href="http://www.xerox.com/rmlna">www.xerox.com/rmlna</a></li><li>– Europe: <a href="http://www.xerox.com/rmleu">www.xerox.com/rmleu</a></li></ul></li><li>2. Verify that the paper type is selected on the control panel and in the print driver.</li><li>3. If the problem persists, follow these steps:<ol data-bbox="708 531 1487 741" style="list-style-type: none"><li>a. At the control panel, touch <b>Device &gt; Information Pages &gt; Troubleshooting Print Quality Page &gt; Print</b>. The Repeating Defects Page prints with instructions for identifying defective units.</li><li>b. To correct the problem, replace the items identified on the Repeating Defects Page.</li></ol></li><li>4. If the problem continues, replace the transfer belt cleaner. If you replace the transfer belt cleaner, reset the counter:<ol data-bbox="708 835 1487 1171" style="list-style-type: none"><li>a. At the control panel, press <b>Log In</b>. Enter system administrator login information, then touch <b>Done</b>. For details, refer to the <i>System Administrator Guide</i>.</li><li>b. Touch <b>Device &gt; Tools &gt; Device Settings</b>.</li><li>c. Scroll, then touch <b>Supplies &gt; Supply Counter Reset</b>.</li><li>d. Touch <b>Transfer Belt Cleaner</b>.</li><li>e. Touch <b>Confirm Reset</b>.</li><li>f. To close the pop-up window, touch <b>X</b>, touch <b>admin</b>, then select <b>Logout</b>.</li></ol></li></ol>

## Solving Print-Quality Problems (continued)

Problem	Solution
<p><b>Poor Transparency Print Quality</b> Print-quality defects are occurring on transparency film:</p> <ul style="list-style-type: none"><li>• Light or dark spots</li><li>• Smeared toner</li><li>• Light bands on print</li></ul>	<p>Use only Xerox® Transparencies.</p> <p><b>CAUTION:</b> Using non-Xerox® transparencies can cause print-quality problems or damage to the fuser. Damage caused by using unsupported media is not covered by the Xerox® Warranty, Service Agreement, or Total Satisfaction Guarantee.</p>
<p><b>Grays are Not Neutral</b> The grays on the printed page are not neutral; they contain color tints.</p>	<p>Calibrate the printer colors. The calibration process adjusts the printer color balance.</p> <ol style="list-style-type: none"><li>1. At the control panel, touch <b>Device &gt; Tools &gt; Troubleshooting &gt; Calibration &gt; Print Calibration</b>.</li><li>2. Follow the onscreen instructions to run the Print Calibration procedure.</li></ol>
<p><b>Colors Vary Between Computers</b> The colors printed from one computer do not match the colors printed from a different computer.</p>	<ol style="list-style-type: none"><li>1. Confirm that the print driver settings for Print Quality, Color Correction, and Color By Words are identical on both computers.</li><li>2. Adjust the settings as needed.</li></ol> <p><b>Note:</b> Print driver settings override the settings that are made at the printer control panel.</p>
<p><b>Colors Do Not Match</b> The color produced by the printer is different from the color that it must match.</p>	<p>For more information about color matching, go to the Online Support Assistant at <a href="http://www.xerox.com/office/support">www.xerox.com/office/support</a>.</p>
<p><b>Printed Colors Do Not Match Monitor Colors</b> The color produced by the printer looks different from the color that appears on the computer monitor.</p>	<p>To view information about color matching between the monitor and the printed document, go to the Online Support Assistant at <a href="http://www.xerox.com/office/support">www.xerox.com/office/support</a>.</p>

## Print-Quality Settings

The Print-Quality mode and Color Corrections options directly control the quality of your prints. You can change these settings in the print driver. Select the setting that is best suited for your print job.

### Print-Quality Mode

- **Enhanced** mode is the general-purpose mode for crisp, bright color prints. Enhanced mode balances speed with quality.
- **High Resolution** mode is a high-quality mode that creates fine lines and detail. High Resolution mode is recommended for vibrant, saturated color prints. High Resolution mode balances quality over speed.
- **Toner Saver** mode reduces the amount of toner used for print jobs and is useful for draft-quality output. Print quality is slightly lower than using Standard mode.

### Color Corrections

Color corrections are available on the Image Options tab in the print driver. The Preview window appears on the right side of the Image Options tab. When the Preview check box is selected, color correction appears in the Preview window. Selecting and clearing the Preview check box allows you to compare the corrected image to the uncorrected image.

To adjust the color characteristics of your print job, select the Color Correction tab, then select options as needed.

- **Xerox Black and White Conversion** converts the colors to grayscale, producing a black and white print job. This setting is useful for creating black and white master documents for photocopying or faxing.
- **Color Correction** provides options to match the printer colors as closely as possible to colors on other devices, such as your computer screen or a printing press.
  - **Automatic** applies the best color correction to each graphic element of the document: text, artwork, and photographs.
  - **Simulate LCD Display** approximates the print job color to the colors on a LCD computer monitor.
  - **sRGB Display** approximates the print job color to an RGB (red, green, blue) display.
  - **None** removes all color correction. This option is the best choice when working with color specified within your application or operating system.
- **Xerox Automatic Color** applies the best color correction to each graphic element of the document, including text, artwork, and photographs.
- **Custom Automatic Color** provides more options for customizing colors in your print job. Use one selection to adjust the color of the text and graphics. Use the other selection to adjust the color correction applied to images. You can apply a wide range of color options to each element to simulate the outputs of different color devices.

To adjust colors using descriptive phrases, select the **Color By Words** tab. From the menus, select the phrases to build a sentence that describes the color adjustment that you want. You can build more than one sentence for the print job, affecting one color or an entire range of colors.

To change settings for each individual color parameter, select the **Color Adjustments** tab, then adjust the sliders. The sliders allow you to select a continuous range of adjustment for each of the following:

- Lightness
- Contrast
- Saturation
- Cyan to Red
- Magenta to Green
- Yellow to Blue

For more information on color matching and ICC profiles, go to [www.xerox.com/office/support](http://www.xerox.com/office/support).

# Fehlerbehebung bei der Druckqualität

Normalerweise wird mit dem Xerox® AltaLink® C8230/C8235/C8245/C8255/C8270 stets eine einwandfreie Ausgabequalität erzielt. Sollten Probleme mit der Druck- oder Kopierqualität auftreten, können die Informationen auf diesen Seiten zur Fehlerbehebung herangezogen werden. Ausführliche Online-Supportinformationen siehe [www.xerox.com/office/support](http://www.xerox.com/office/support).

**ACHTUNG:** Schäden, die durch nicht unterstütztes Druckmaterial verursacht wurden, fallen nicht unter die Xerox®-Garantie, den Servicevertrag oder die Total Satisfaction Garantie (umfassende Garantie). Die Total Satisfaction Garantie (umfassende Garantie) wird in den USA und in Kanada angeboten. Für die übrigen Länder kann ein anderer Gewährleistungsumfang gelten. Nähere Informationen erteilt der lokale Xerox-Partner.

## Materialart

**ACHTUNG:** Wenn in einen Behälter eine andere Materialart eingelegt wird, muss die Materialeinstellung am Steuerpult entsprechend aktualisiert werden. Wird die Einstellung der Materialart nicht geändert, kann es zu Einbußen bei der Druckqualität und Schäden am Fixiermodul kommen.

Das beste Ergebnis wird mit empfohlenen Druckmaterialien von Xerox® erzielt. Mit Xerox®-Druckmaterialien wird auf dem Xerox® AltaLink® C8230/C8235/C8245/C8255/C8270 eine optimale Ausgabequalität erzielt. Xerox®-Druckmaterialien können bestellt werden unter:

[www.xerox.com/office/supplies](http://www.xerox.com/office/supplies).

Eine umfassende Liste der für den Drucker empfohlenen Druckmaterialien ist zu finden unter:

- Nordamerika: [www.xerox.com/rmlna](http://www.xerox.com/rmlna)
- Europa: [www.xerox.com/rmleu](http://www.xerox.com/rmleu)

## Beheben von Problemen mit der Druckqualität

Die folgenden Tabellen enthalten Lösungen zu speziellen Druckqualitätsproblemen.

**Hinweis:** Für die Darstellungen wurde Längsseitenzufuhr gewählt. Bei Schmalseitenzufuhr erscheinen Druckbildmängel um 90 Grad gedreht. Die Darstellungen dienen nur der Veranschaulichung. Nicht alle dargestellten Seiten werden gedruckt.

# Beheben von Problemen mit der Druckqualität

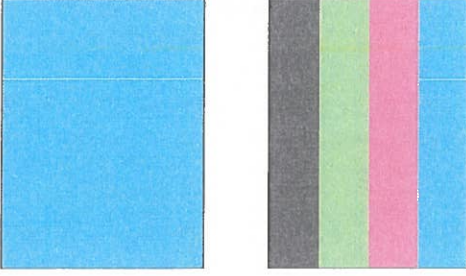
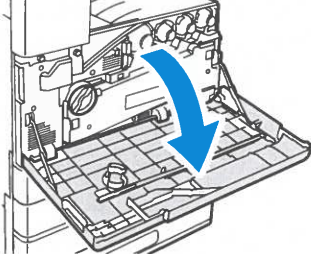
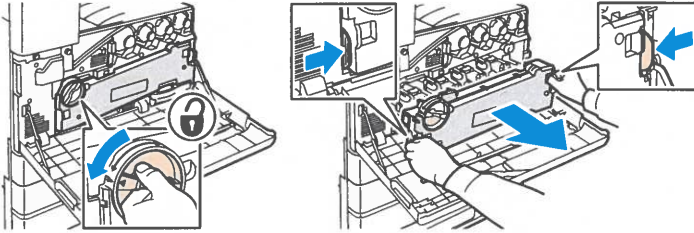
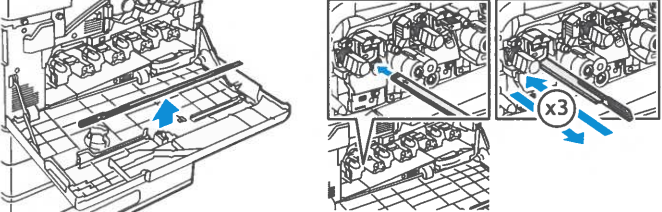
Problem	Lösung
<p data-bbox="97 220 568 252"><b>Helle Linien oder Streifen bei einer Farbe</b></p> 	<ol data-bbox="657 220 974 252" style="list-style-type: none"><li>1. Vordere Abdeckung öffnen.</li></ol>  <ol data-bbox="657 535 1380 630" style="list-style-type: none"><li>2. Zum Entriegeln des Bandspannshebels auf der linken Seite des Druckers den Hebel drehen, und dann die Abdeckung der Trommeleinheit öffnen.</li></ol>  <ol data-bbox="657 892 1429 987" style="list-style-type: none"><li>3. Den LED-Druckkopfreiniger zwei- bis dreimal bis zum Anschlag herausziehen und wieder einschieben. Diesen Vorgang für alle vier Tonereinheiten ausführen.</li></ol> <p data-bbox="698 997 1461 1060"><b>Hinweis:</b> Die LED-Druckkopfreiniger so weit wie möglich herausziehen und bis zum Anschlag wieder einschieben. Keine Gewalt anwenden.</p>  <p data-bbox="657 1333 1453 1480">Tritt das Problem weiterhin auf, prüfen, ob die Ursache des Problems bei der Trommeleinheit liegt. Dazu die betreffende Trommeleinheit mit der Trommeleinheit einer anderen Farbe vertauschen. Tritt das Problem bei derselben Trommeleinheit auch an der neuen Position auf, die Trommeleinheit austauschen.</p>

## Beheben von Problemen mit der Druckqualität (Fortsetzung)

Problem	Lösung
<p><b>Unvollständige Fixierung</b></p> <p>Die Ausgabe weist Auslassungen auf und/oder der Toner lässt sich leicht abreiben.</p> 	<ol style="list-style-type: none"><li>1. Sicherstellen, dass das Druckmaterial für den Drucker geeignet ist und ordnungsgemäß eingelegt wurde. Eine umfassende Liste der für den Drucker empfohlenen Druckmaterialien ist zu finden unter:<ul style="list-style-type: none"><li>– Nordamerika: <a href="http://www.xerox.com/rmlna">www.xerox.com/rmlna</a></li><li>– Europa: <a href="http://www.xerox.com/rmleu">www.xerox.com/rmleu</a></li></ul></li><li>2. Überprüfen, ob am Steuerpult und im Druckertreiber das richtige Druckmaterial ausgewählt wurde.</li><li>3. Tritt das Problem weiterhin auf, einen der folgenden Schritte ausführen:<ol style="list-style-type: none"><li>a. Bei Festformbehältern als Administrator anmelden, <b>Gerät &gt; Verwaltung &gt; Geräteeinstellung &gt; Materialverwaltung &gt; Behältereinstellungen</b> antippen. Den Behälter auswählen, <b>Bearbeiten</b> antippen und die Materialart ändern. <b>Hinweis:</b> Anmeldung als Systemadministrator vornehmen, wenn die Einstellung von Format, Art oder Farbe des Materials in einem Festformatbehälter geändert werden soll.</li><li>b. Bei Behältern, für die der Modus „Frei einstellbar“ ausgewählt ist:<ul style="list-style-type: none"><li>• Behälter 1-4 und 6: Den ausgewählten Materialbehälter öffnen und wieder schließen.</li><li>• Behälter 5: Das Druckmaterial herausnehmen und wieder einlegen.</li></ul>Am Steuerpult wird zum Bestätigen oder Ändern der Materialart aufgefordert.</li><li>c. Am Touchscreen <b>Art</b> antippen und dann einen der folgenden Schritte ausführen:<ul style="list-style-type: none"><li>• Richtige Materialart auswählen und dann <b>Bestätigen</b> antippen.</li><li>• Nächstschwerere Materialart auswählen und dann <b>Bestätigen</b> antippen.</li></ul><b>Hinweis:</b> Folgende Materialarten stehen zur Auswahl (nach Gewicht in aufsteigender Reihenfolge):<ul style="list-style-type: none"><li>• Ungestrichenes Papier: Normalpapier, Leichtkarton, Karton und schwerer Karton.</li><li>• Gestrichenes Papier: Leichter Glanzkarton, Glanzkarton und schwerer Glanzkarton.</li></ul></li></ol></li></ol>

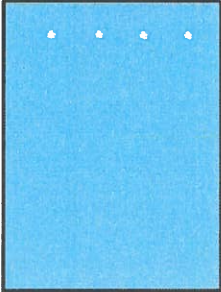
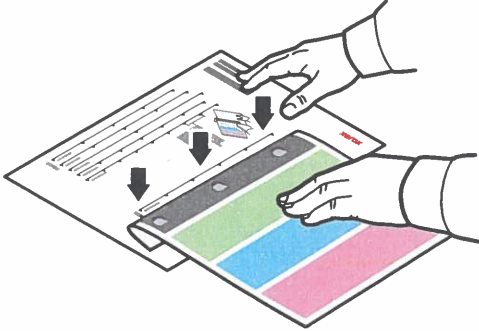

## Beheben von Problemen mit der Druckqualität (Fortsetzung)

Problem	Lösung
<p><b>Wiederholte Fehler</b></p> <p>Die Ausgabe weist in Zufuhrrichtung Punkte oder Linien auf, die in regelmäßigen Abständen wiederkehren und bei allen Farben bzw. in unbedruckten Bereichen auftreten.</p>  <p>Die Ausgabe weist in Zufuhrrichtung Punkte oder Linien auf, die in regelmäßigen Abständen wiederkehren, aber nur bei einer Farbe auftreten.</p> 	<ol style="list-style-type: none"><li>1. Am Steuerpult <b>Gerät &gt; Verwaltung &gt; Fehlerbehebung &gt; Hilfsseiten &gt; Seite für Wiederholungsfehler &gt; Drucken</b> antippen. Die Seite für Wiederholungsfehler mit Anweisungen zum Ermitteln der defekten Komponente(n) wird ausgegeben.</li><li>2. Zum Beheben des Problems die anhand der Seite für Wiederholungsfehler ermittelten Teile austauschen. </li><li>3. Wurde die Übertragungswalze ausgetauscht, den Zähler zurücksetzen:<ol style="list-style-type: none"><li>a. Am Steuerpult die Taste <b>Anmelden/Abmelden</b> drücken. Die Anmeldedaten des Systemadministrators eingeben und <b>Eingabe</b> antippen. Weitere Informationen siehe <i>System Administrator Guide (Systemadministratorhandbuch)</i>.</li><li>b. <b>Gerät &gt; Verwaltung &gt; Geräteeinstellung</b> antippen.</li><li>c. Bildlauf durchführen und <b>Austauschmodule &gt; Verbrauchsmaterialzähler zurücksetzen</b> antippen.</li><li>d. <b>Sekundäre Übertragungswalze</b> antippen.</li><li>e. <b>Zähler zurücksetzen</b> antippen.</li><li>f. Zum Schließen des Popupfensters das <b>X</b>, dann <b>admin</b> antippen und <b>Abmelden</b> auswählen.</li></ol></li></ol>

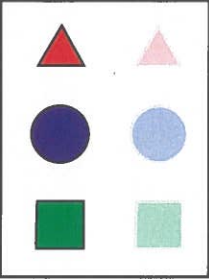
## Beheben von Problemen mit der Druckqualität (Fortsetzung)

Problem	Lösung
<p><b>Versetztes Bild</b></p> <p>Der am häufigsten vorkommende Versatzfehler besteht darin, dass ein Druckbild im Abstand von 95 mm (3,75 Zoll) in Zufuhrrichtung wiederholt wird, so dass es ggf. zu einer Überlagerung kommt.</p> <p><b>Hinweis:</b> Bei anderen Abständen die Ursache anhand der Seite für Wiederholungsfehler ermitteln.</p> 	<ol style="list-style-type: none"><li>1. Prüfen, ob das Druckmaterial für den Drucker geeignet ist und ordnungsgemäß eingelegt wurde. Eine umfassende Liste der für den Drucker empfohlenen Druckmaterialien ist zu finden unter:<ul style="list-style-type: none"><li>– Nordamerika: <a href="http://www.xerox.com/rmlna">www.xerox.com/rmlna</a></li><li>– Europa: <a href="http://www.xerox.com/rmleu">www.xerox.com/rmleu</a></li></ul></li><li>2. Überprüfen, ob am Steuerpult und im Druckertreiber das richtige Druckmaterial ausgewählt wurde. <b>Hinweis:</b> Anmeldung als Systemadministrator vornehmen, wenn die Einstellung von Format, Art oder Farbe des Materials in einem Festformatbehälter geändert werden soll.</li><li>3. Tritt das Problem weiterhin auf, einen der folgenden Schritte ausführen:<ol style="list-style-type: none"><li>a. Bei Festformbehältern als Administrator anmelden, <b>Gerät &gt; Verwaltung &gt; Geräteeinstellung &gt; Materialverwaltung &gt; Behältereinstellungen</b> antippen. Den Behälter auswählen, <b>Bearbeiten</b> antippen und die Materialart ändern.</li><li>b. Bei Behältern, für die der Modus „Frei einstellbar“ ausgewählt ist:<ul style="list-style-type: none"><li>• Behälter 1-4 und 6: Den ausgewählten Materialbehälter öffnen und wieder schließen.</li><li>• Behälter 5: Das Druckmaterial herausnehmen und wieder einlegen.</li></ul>Am Steuerpult wird zum Bestätigen oder Ändern der Materialart aufgefordert.</li><li>c. Am Touchscreen <b>Art</b> antippen und dann einen der folgenden Schritte ausführen:<ul style="list-style-type: none"><li>• Richtige Materialart auswählen und dann <b>Bestätigen</b> antippen.</li><li>• Nächstschwerere Materialart auswählen und dann <b>Bestätigen</b> antippen.</li></ul><b>Hinweis:</b> Folgende Materialarten stehen zur Auswahl (nach Gewicht in aufsteigender Reihenfolge):<ul style="list-style-type: none"><li>• Ungestrichenes Papier: Normalpapier, Leichtkarton, Karton und schwerer Karton.</li><li>• Gestrichenes Papier: Leichter Glanzkarton, Glanzkarton und schwerer Glanzkarton.</li></ul></li><li>d. Ursache mithilfe der Seite für Wiederholungsfehler ermitteln. Weitere Informationen siehe vorige Seite.</li></ol></li></ol>

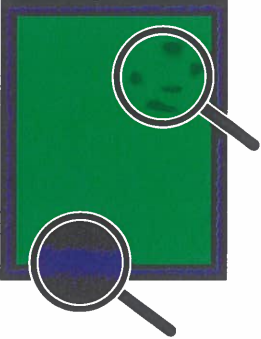
## Beheben von Problemen mit der Druckqualität (Fortsetzung)

Problem	Lösung
<p><b>Fleckige Ausgabe bei hoher Tonerdichte</b> Schwarzöne erscheinen blau</p> 	<ol style="list-style-type: none"><li>1. Sicherstellen, dass das Druckmaterial für den Drucker geeignet ist und ordnungsgemäß eingelegt wurde. Eine umfassende Liste der für den Drucker empfohlenen Druckmaterialien ist zu finden unter:<ul style="list-style-type: none"><li>– Nordamerika: <a href="http://www.xerox.com/rmlna">www.xerox.com/rmlna</a></li><li>– Europa: <a href="http://www.xerox.com/rmleu">www.xerox.com/rmleu</a></li></ul></li><li>2. Überprüfen, ob am Steuerpult und im Druckertreiber das richtige Druckmaterial ausgewählt wurde.</li></ol> <p>Tritt das Problem weiterhin auf, den Kundendienst anfordern.</p>
<p><b>Falsche Farbausrichtung</b> Es treten Farbverschiebungen bzw. -überlagerungen auf.</p> 	<p>Vordere Abdeckung öffnen und wieder schließen. Mit dem nächsten Druckauftrag wird automatisch eine Kalibrierung zur Ausrichtung der Farben durchgeführt.</p>
<p><b>Alle Farben zu hell oder zu dunkel</b> Farben erscheinen blass oder zu dunkel auf dem Druck oder der Kopie.</p>	<ol style="list-style-type: none"><li>1. Sicherstellen, dass das Druckmaterial für den Drucker geeignet ist und ordnungsgemäß eingelegt wurde. Eine umfassende Liste der für den Drucker empfohlenen Druckmaterialien ist zu finden unter:<ul style="list-style-type: none"><li>– Nordamerika: <a href="http://www.xerox.com/rmlna">www.xerox.com/rmlna</a></li><li>– Europa: <a href="http://www.xerox.com/rmleu">www.xerox.com/rmleu</a></li></ul></li><li>2. Überprüfen, ob am Steuerpult und im Druckertreiber das richtige Druckmaterial ausgewählt wurde.</li><li>3. Die Druckerfarben kalibrieren. Beim Kalibrieren werden Farbabgleich und -helligkeit eingestellt. Am Steuerpult <b>Gerät &gt; Verwaltung &gt; Fehlerbehebung &gt; Kalibrierung &gt; Druckkalibrierung</b> oder <b>Kopierkalibrierung</b> antippen. Kalibrierung anhand der Bildschirmanweisungen durchführen.</li></ol> <p><b>Hinweis:</b> Informationen zum Ändern der Helligkeit im PostScript-Treiber für das jeweilige Betriebssystem siehe das Kapitel <i>Drucken</i> im <i>Benutzerhandbuch</i>.</p>

## Beheben von Problemen mit der Druckqualität (Fortsetzung)

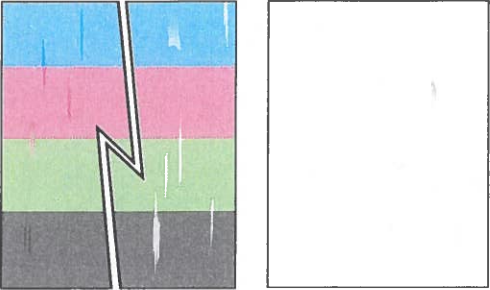
Problem	Lösung
<p><b>Striche, verschmierte Stellen oder Streifen</b> Die Ausgabe weist dunkle oder helle Stellen auf (alle Farben bzw. nicht bedruckte Bereiche).</p> 	<ol style="list-style-type: none"><li>1. Sicherstellen, dass das Druckmaterial für den Drucker geeignet ist und ordnungsgemäß eingelegt wurde. Eine umfassende Liste der für den Drucker empfohlenen Druckmaterialien ist zu finden unter:<ul style="list-style-type: none"><li>– Nordamerika: <a href="http://www.xerox.com/rmlna">www.xerox.com/rmlna</a></li><li>– Europa: <a href="http://www.xerox.com/rmleu">www.xerox.com/rmleu</a></li></ul></li><li>2. Überprüfen, ob am Steuerpult und im Druckertreiber das richtige Druckmaterial ausgewählt wurde.</li><li>3. Tritt das Problem weiterhin auf, die folgenden Schritte ausführen:<ol style="list-style-type: none"><li>a. Am Steuerpult <b>Gerät &gt; Infoseiten &gt; Seite zur Fehlerbehebung bei Druckqualitätsproblemen &gt; Drucken</b> antippen. Die Seite für Wiederholungsfehler mit Anweisungen zum Ermitteln der defekten Komponente(n) wird ausgegeben.</li><li>b. Zum Beheben des Problems die anhand der Seite für Wiederholungsfehler ermittelten Teile austauschen.</li></ol></li><li>4. Tritt das Problem weiterhin auf, den Übertragungsbandreiniger austauschen. Wurde der Übertragungsbandreiniger ausgetauscht, den Zähler zurücksetzen:<ol style="list-style-type: none"><li>a. Am Steuerpult die Taste <b>Anmelden/Abmelden</b> drücken. Die Anmeldedaten des Systemadministrators eingeben und <b>Fertig</b> antippen. Weitere Informationen siehe <i>System Administrator Guide (Systemadministratorhandbuch)</i>.</li><li>b. <b>Gerät &gt; Verwaltung &gt; Geräteeinstellung</b> antippen.</li><li>c. Bildlauf durchführen und <b>Austauschmodule &gt; Verbrauchsmaterialzähler zurücksetzen</b> antippen.</li><li>d. <b>Übertragungsbandreiniger</b> antippen.</li><li>e. <b>Zähler zurücksetzen - Bestätigung</b> antippen.</li><li>f. Zum Schließen des Popupfensters das <b>X</b>, dann <b>admin</b> antippen und <b>Abmelden</b> auswählen.</li></ol></li></ol>

## Beheben von Problemen mit der Druckqualität (Fortsetzung)

Problem	Lösung
<p><b>Mangelhafte Ausgabequalität beim Drucken auf Klarsichtfolien</b></p> <p>Beim Drucken auf Klarsichtfolien treten Qualitätsmängel auf:</p> <ul style="list-style-type: none"><li>• Helle oder dunkle Flecken</li><li>• Verwischter Toner</li><li>• Helle Streifen</li></ul>	<p>Nur Xerox®-Klarsichtfolien verwenden.</p> <p><b>ACHTUNG:</b> Folien von anderen Herstellern als Xerox® können Druckqualitätsprobleme bzw. Schäden an der Fixieranlage verursachen. Schäden, die durch nicht unterstütztes Druckmaterial verursacht wurden, fallen nicht unter die Xerox®-Garantie, den Servicevertrag oder die Total Satisfaction Garantie (umfassende Garantie).</p>
<p><b>Grautöne haben Farbstich</b></p> <p>Grautöne erscheinen in der Ausgabe nicht neutral, sondern weisen einen Farbstich auf.</p>	<p>Die Druckerfarben kalibrieren. Bei der Kalibrierung werden die Farben auf dem Drucker abgestimmt.</p> <ol style="list-style-type: none"><li>1. Am Steuerpult <b>Gerät &gt; Verwaltung &gt; Fehlerbehebung &gt; Kalibrierung &gt; Druckkalibrierung</b> antippen.</li><li>2. Druckkalibrierungsverfahren gemäß Anweisungen auf dem Bildschirm durchführen.</li></ol>
<p><b>Farben variieren von Computer zu Computer</b></p> <p>Bei der Dokumentausgabe von unterschiedlichen Computern stimmen die Farben nicht überein.</p>	<ol style="list-style-type: none"><li>1. Sicherstellen, dass die Treibereinstellungen für Druckqualität, Farbkorrektur und „Farbe nach Wörtern“ auf beiden Computern identisch sind.</li><li>2. Ggf. die Einstellungen anpassen.</li></ol> <p><b>Hinweis:</b> Die Einstellungen im Druckertreiber haben Vorrang vor den am Steuerpult des Druckers vorgenommenen Einstellungen.</p>
<p><b>Farben stimmen nicht überein</b></p> <p>Die ausgegebene Farbe entspricht nicht der Zielfarbe.</p>	<p>Weitere Informationen über die Farbabstimmung siehe Online-Support-Assistent unter <a href="http://www.xerox.com/office/support">www.xerox.com/office/support</a>.</p>
<p><b>Farben auf der Ausgabe stimmen nicht mit den Farben am Bildschirm überein</b></p> <p>Die ausgegebene Farbe entspricht nicht der am Computerbildschirm angezeigten Farbe.</p>	<p>Informationen zur Farbabstimmung zwischen Bildschirm und gedrucktem Dokument siehe Online-Support-Assistent unter: <a href="http://www.xerox.com/office/support">www.xerox.com/office/support</a>.</p>

## Einstellungen für die Druckqualität

Der Druckqualitätsmodus und die Farbkorrekturoptionen haben direkten Einfluss auf die Druckqualität. Diese Einstellungen können im Druckertreiber geändert werden. Die für den Druckauftrag am besten geeignete Einstellung wählen.

### Druckqualitätsmodus

- **Optimiert:** Dies ist der Allzweckmodus für frische, leuchtende Farbdrucke. Der Modus „Optimiert“ sorgt für ein ausgewogenes Verhältnis zwischen Geschwindigkeit und Qualität.
- **Hohe Auflösung:** Dieser Modus sorgt für hohe Qualität mit feiner Linien- und Detailzeichnung. Der Modus „Hohe Auflösung“ wird für kräftige, satte Farbdrucke empfohlen. Beim Modus „Hohe Auflösung“ hat Qualität Vorrang vor der Geschwindigkeit.
- **Tonersparbetrieb:** In diesem für Entwurfsdrucke geeigneten Modus wird der Tonerverbrauch reduziert. Die Druckqualität ist etwas geringer als beim Standardmodus.

### Farbkorrektur

Die Farbkorrektur ist auf der Registerkarte „Bildqualität“ im Druckertreiber verfügbar. Das Vorschauenfenster befindet sich rechts auf der Registerkarte „Bildqualität“. Wenn das Kontrollkästchen „Vorschau“ aktiviert ist, wird die Farbkorrektur im Vorschauenfenster angezeigt. Das korrigierte Bild kann mit dem nicht korrigierten Bild verglichen werden, indem die Vorschauoption wechselweise aktiviert und deaktiviert wird.

Zum Anpassen der Farben eines Druckauftrags die Registerkarte „Farbkorrektur“ und dann die gewünschten Optionen auswählen.

- **Xerox-Schwarzweißumwandlung** konvertiert die Farben in Graustufen. Die Ausgabe erfolgt in Schwarzweiß. Diese Einstellung eignet sich zum Erstellen von Schwarzweißvorlagen zum Kopieren oder Übermitteln per Fax.
- **Farbkorrektur** bietet Optionen zur möglichst genauen Abstimmung der Druckerfarben auf die von anderen Geräten produzierten im Farben, zum Beispiel von einem Computerbildschirm oder einem bestimmten Drucksystem.
  - **Automatisch** wendet auf jedes Grafikelement des Dokuments die optimale Farbkorrektur an: Text, Grafiken und Fotos.
  - **LCD-Anzeige simulieren** nähert die Farbe des Druckauftrags an die Farben eines LCD-Computermonitors an.
  - **sRGB-Anzeige simulieren** nähert die Farbe des Druckauftrags an die Farben einer RGB-Anzeige (Rot, Grün, Blau) an.
  - **Aus:** Farbkorrektur deaktiviert. Diese Einstellung ist die beste Wahl, wenn die Farbe in der Anwendung oder im Betriebssystem spezifiziert wurde.
- **Xerox-Autofarbe** wendet auf jedes grafische Element (Text, Grafiken, Fotos) die optimale Farbkorrektur an.
- **Benutzerdefinierte automatische Farbe** stellt zusätzliche Optionen zum Anpassen der Farben im Druckauftrag bereit. Eine der Einstellungen zum Anpassen der Farbe von Text und Grafiken auswählen. Die andere Einstellung zum Anpassen der auf die Bilder angewendeten Farbkorrektur verwenden. Auf jedes Element können viele verschiedene Farboptionen angewendet werden, um die Ausgabe verschiedener Farbgeräte zu simulieren.

Zum Anpassen von Farben mit beschreibenden Ausdrücken die Registerkarte **Farbe nach Wörtern** auswählen. Aus den Menüs die Wörter für den Satz auswählen, der die gewünschte Farbanpassung beschreibt. Es können mehrere Sätze auf einen Druckauftrag angewendet werden. Die Korrektur kann für eine einzelne Farbe oder ein gesamtes Farbspektrum durchgeführt werden.

Zum Ändern der Einstellungen einzelner Farbparameter die Registerkarte **Farbanpassung** auswählen und die Schieberegler anpassen. Mithilfe der Skalen kann für jedes nachstehend aufgeführte Element ein durchgängiger Bereich mit Anpassungen ausgewählt werden:

- Helligkeit
- Kontrast
- Sättigung
- Cyan in Rot
- Magenta in Grün
- Gelb in Blau

Weitere Informationen zu Farbanpassung und ICC-Profilen siehe [www.xerox.com/office/support](http://www.xerox.com/office/support).

# Troubleshooting Print Quality

Your Xerox® AltaLink® C8230/C8235/C8245/C8255/C8270 Color Multifunction Printer is designed to produce high-quality color prints consistently. If you observe print-quality problems, use the information on these pages to troubleshoot the problems. For detailed online support information, go to [www.xerox.com/office/support](http://www.xerox.com/office/support).

**CAUTION:** The Xerox® warranty, Service Agreement, or Total Satisfaction Guarantee does not cover damage caused by using unsupported paper, transparencies, or other specialty media. The Total Satisfaction Guarantee is available in the United States and Canada. Coverage can vary outside of these areas. For details, contact your local representative.

## Paper Type

**CAUTION:** If you change the type of paper in the tray, change the paper type at the control panel to match the paper in the tray. If you fail to change the paper type, it can cause print-quality problems and damage the fuser.

For the best results, only use recommended Xerox® paper and media. Xerox® paper and media are guaranteed to produce excellent results on your Xerox® AltaLink® C8230/C8235/C8245/C8255/C8270 Color Multifunction Printer. To order Xerox® paper and media, go to [www.xerox.com/office/supplies](http://www.xerox.com/office/supplies).

For a complete list of recommended paper for your printer, go to:

- North America: [www.xerox.com/rmlna](http://www.xerox.com/rmlna)
- Europe: [www.xerox.com/rmleu](http://www.xerox.com/rmleu)

## Solving Print-Quality Problems

Use the following tables to find specific solutions to print-quality problems.

**Note:** The images that appear represent long-edge feed prints. If you print short-edge feed, the print-quality defects are rotated 90 degrees. The images that appear are for reference only. Not all pages represented are printed.

# Solving Print-Quality Problems

## Problem

### Light Lines or Streaks in One Color

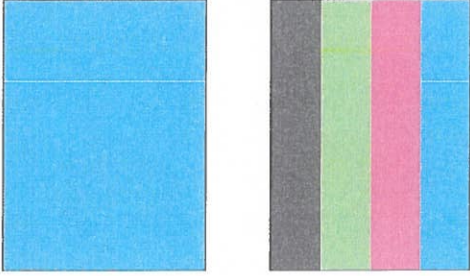

## Solution

1. Open the front cover.



2. To unlock the belt tension lever, on the left side of the printer, rotate the belt tension lever, then open the drum cartridge cover.

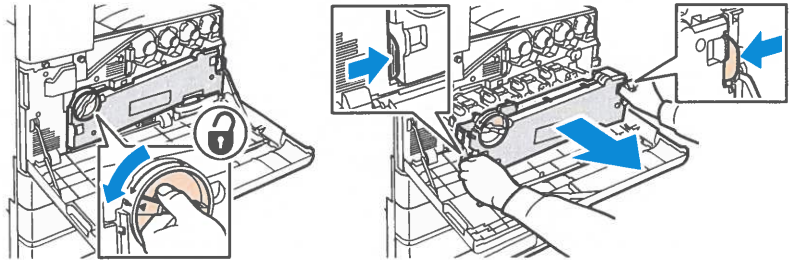

3. Pull out the LED print head cleaner until it stops, then move it all the way in and out two or three times. Repeat this process for all four toner units.

**Note:** Ensure that you pull the LED print head cleaners out as far as they will go. Push them in as far as they will go. Do not use excessive force.

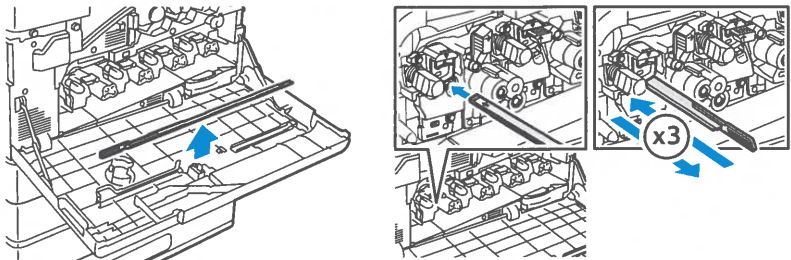



If the problem persists, check if the drum cartridge is causing the problem. To check, switch the suspected drum cartridge with another drum cartridge of a different color. If the problem occurs where you move the suspected drum cartridge, replace the suspected drum cartridge.

## Solving Print-Quality Problems (continued)

Problem	Solution
<p data-bbox="99 233 315 260"><b>Incomplete Fusing</b></p> <p data-bbox="99 275 605 331">Toner appears to be missing from the print, or rubs off easily.</p> 	<ol style="list-style-type: none"><li data-bbox="670 233 1458 289">1. Verify that the paper you are using is the correct type for the printer and is properly loaded. For a complete list of recommended paper for your printer, go to:<ul style="list-style-type: none"><li data-bbox="708 348 1187 375">– North America: <a href="http://www.xerox.com/rmlna">www.xerox.com/rmlna</a></li><li data-bbox="708 390 1101 417">– Europe: <a href="http://www.xerox.com/rmleu">www.xerox.com/rmleu</a></li></ul></li><li data-bbox="670 432 1463 489">2. Verify that the paper type is selected on the control panel and in the print driver.</li><li data-bbox="670 504 1484 638">3. If the problem persists, do one of the following:<ol style="list-style-type: none"><li data-bbox="708 548 1484 638">a. For dedicated trays, log in as admin, touch <b>Device &gt; Tools &gt; Device Settings &gt; Paper Management &gt; Tray Settings</b>. Select the tray, touch <b>Edit</b>, then change the paper type. <b>Note:</b> To change the size, type, or color of paper in a dedicated tray when the control panel is locked, log in as the system administrator.</li><li data-bbox="708 726 1430 840">b. For trays that are set to Fully Adjustable:<ul style="list-style-type: none"><li data-bbox="745 770 1430 798">• Trays 1–4 and 6: Open, then close the selected paper tray.</li><li data-bbox="745 812 1230 840">• Tray 5: Remove, then reinsert the paper.</li></ul>The control panel prompts you to confirm or change the paper type.</li><li data-bbox="708 898 1430 1012">c. At the touch screen, touch <b>Type</b>, then do one of the following:<ul style="list-style-type: none"><li data-bbox="745 942 1344 970">• Select the correct paper type, then touch <b>Confirm</b>.</li><li data-bbox="745 984 1430 1012">• Select the next heavier type of paper, then touch <b>Confirm</b>.</li></ul></li></ol></li></ol> <p data-bbox="703 1026 1227 1054"><b>Note:</b> Paper types from lightest to heaviest are:</p> <ul style="list-style-type: none"><li data-bbox="745 1068 1458 1125">• For uncoated paper: Plain, Lightweight Cardstock, Cardstock, and Heavyweight Cardstock.</li><li data-bbox="745 1140 1398 1197">• For coated paper: Lightweight Glossy Cardstock, Glossy Cardstock, and Heavyweight Glossy Cardstock.</li></ul>

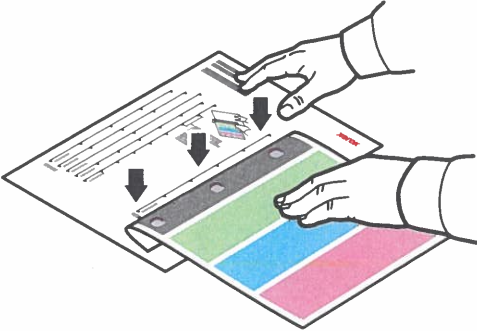

## Solving Print-Quality Problems (continued)

Problem	Solution
<p data-bbox="99 237 313 264"><b>Repeating Defects</b></p> <p data-bbox="99 279 574 401">Spots or lines appear at regular intervals on the page in the direction that the paper moves through the printer in all colors or in non-printed areas.</p>  <p data-bbox="99 730 574 821">Spots or lines appear at regular intervals on the page, in the direction the paper moves through the printer, and in one color only.</p> 	<ol data-bbox="672 237 1487 1182" style="list-style-type: none"><li data-bbox="672 237 1487 296">1. At the control panel, touch <b>Device &gt; Tools &gt; Troubleshooting &gt; Support Pages &gt; Repeating Defects Page &gt; Print</b>. The Repeating Defects Page prints with instructions for identifying defective units.</li><li data-bbox="672 384 1487 443">2. To correct the problem, replace items identified on the Repeating Defects Page.</li><li data-bbox="672 804 1487 1182">3. If you replaced the the transfer roller, reset the counter:<ol data-bbox="708 846 1487 1182" style="list-style-type: none"><li data-bbox="708 846 1487 940">a. At the control panel, press <b>Log In</b>. Enter system administrator login information, then touch <b>Enter</b>. For details, refer to the <i>System Administrator Guide</i>.</li><li data-bbox="708 951 1487 982">b. Touch <b>Device &gt; Tools &gt; Device Settings</b>.</li><li data-bbox="708 993 1487 1024">c. Scroll, then touch <b>Supplies &gt; Supply Counter Reset</b>.</li><li data-bbox="708 1035 1487 1066">d. Touch <b>Second Bias Transfer Roll</b>.</li><li data-bbox="708 1077 1487 1108">e. Touch <b>Reset Counter</b>.</li><li data-bbox="708 1119 1487 1182">f. To close the pop-up window, touch <b>X</b>, touch <b>admin</b>, then select <b>Logout</b>.</li></ol></li></ol> 

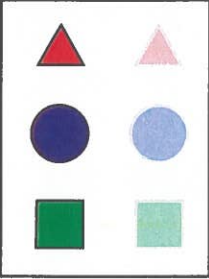
## Solving Print-Quality Problems (continued)

Problem	Solution
<p><b>Offset Image</b></p> <p>The most common offset is toner that appears to be reprinted on the page and placed about 95 mm (3.75 in.) across the page in the direction that the paper moves through the printer.</p> <p><b>Note:</b> For a different distance, use the Repeating Defects Page to identify the cause.</p> 	<ol style="list-style-type: none"><li>1. Verify that the paper you are using is the correct paper type for the printer and is properly loaded. For a complete list of recommended paper for your printer, go to:<ul style="list-style-type: none"><li>– North America: <a href="http://www.xerox.com/rmlna">www.xerox.com/rmlna</a></li><li>– Europe: <a href="http://www.xerox.com/rmleu">www.xerox.com/rmleu</a></li></ul></li><li>2. Verify that the paper type is selected on the control panel and in the print driver. <b>Note:</b> To change the size, type, or color of paper in a dedicated tray when the control panel is locked, log in as the system administrator.</li><li>3. If the problem continues, do one of the following:<ol style="list-style-type: none"><li>a. For dedicated trays, log in as admin, touch <b>Device &gt; Tools &gt; Device Settings &gt; Paper Management &gt; Tray Settings</b>. Select the tray, touch <b>Edit</b>, then change the paper type.</li><li>b. For trays that are set to Fully Adjustable:<ul style="list-style-type: none"><li>• Trays 1–4 and 6: Open, then close the selected paper tray.</li><li>• Tray 5: Remove, then reinsert the paper.</li></ul>The control panel prompts you to confirm or change the paper type.</li><li>c. At the touch screen, touch <b>Type</b>, then do one of the following:<ul style="list-style-type: none"><li>• Select the correct paper type, then touch <b>Confirm</b>.</li><li>• Select the next heavier paper type, then touch <b>Confirm</b>.</li></ul><b>Note:</b> Paper types from lightest to heaviest are:<ul style="list-style-type: none"><li>• For uncoated paper: Plain, Lightweight Cardstock, Cardstock, and Heavyweight Cardstock.</li><li>• For coated paper: Lightweight Glossy Cardstock, Glossy Cardstock, and Heavyweight Glossy Cardstock.</li></ul></li><li>d. To identify the cause, use the Repeating Defects Page. For details, refer to the previous page.</li></ol></li></ol>

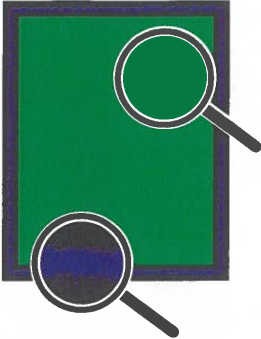
## Solving Print-Quality Problems (continued)

Problem	Solution
<p><b>Heavy Coverage Appears Mottled or Blotchy</b> <b>Blacks Appear Blue</b></p> 	<ol style="list-style-type: none"><li>1. Verify that the paper you are using is the correct type for the printer and is properly loaded. For a complete list of recommended paper for your printer, go to:<ul style="list-style-type: none"><li>– North America: <a href="http://www.xerox.com/rmlna">www.xerox.com/rmlna</a></li><li>– Europe: <a href="http://www.xerox.com/rmleu">www.xerox.com/rmleu</a></li></ul></li><li>2. Verify that the paper type is selected on the control panel and in the print driver.</li></ol> <p>If the problem continues, call for service.</p>
<p><b>Colors Align Incorrectly</b> Color has shifted outside the designated area or is superimposed over another color.</p> 	<p>Open, then close the front door. The printer performs an automatic registration calibration with the next print.</p>
<p><b>All Colors Too Light or Too Dark</b> Colors appear faded or too dark on print or copy.</p>	<ol style="list-style-type: none"><li>1. Verify that the paper you are using is the correct type for the printer and is properly loaded. For a complete list of recommended paper for your printer, go to:<ul style="list-style-type: none"><li>– North America: <a href="http://www.xerox.com/rmlna">www.xerox.com/rmlna</a></li><li>– Europe: <a href="http://www.xerox.com/rmleu">www.xerox.com/rmleu</a></li></ul></li><li>2. Verify that the paper type is selected on the control panel and in the print driver.</li><li>3. Calibrate the printer colors. The calibration procedure adjusts the printer color balance and lightness level. At the control panel, touch <b>Device &gt; Tools &gt; Troubleshooting &gt; Calibration &gt; Print Calibration</b> or <b>Copy Calibration</b>. Follow the onscreen instructions to run the calibration procedure.</li></ol> <p><b>Note:</b> For information about changing the Lightness setting in the PostScript print driver for your operating system, refer to the <i>Printing</i> chapter of the <i>User Guide</i>.</p>

## Solving Print-Quality Problems (continued)

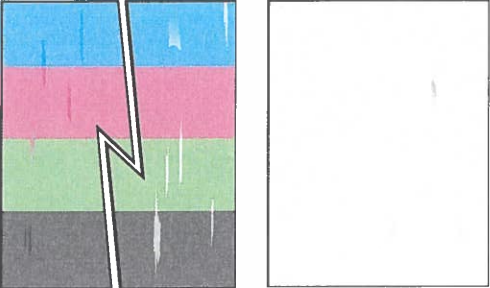
Problem	Solution
<p data-bbox="99 222 407 254"><b>Lines, Smudges, or Streaks</b></p> <p data-bbox="99 262 594 323">Dark or light marks appear on the page in all colors and/or in non-printed areas.</p> 	<ol data-bbox="670 222 1484 1171" style="list-style-type: none"><li>1. Verify that the paper you are using is the correct type for the printer and is properly loaded. For a complete list of recommended paper for your printer, go to:<ul data-bbox="708 338 1425 411" style="list-style-type: none"><li>– North America: <a href="http://www.xerox.com/rmlna">www.xerox.com/rmlna</a></li><li>– Europe: <a href="http://www.xerox.com/rmleu">www.xerox.com/rmleu</a></li></ul></li><li>2. Verify that the paper type is selected on the control panel and in the print driver.</li><li>3. If the problem persists, follow these steps:<ol data-bbox="708 541 1484 751" style="list-style-type: none"><li>a. At the control panel, touch <b>Device &gt; Information Pages &gt; Troubleshooting Print Quality Page &gt; Print</b>. The Repeating Defects Page prints with instructions for identifying defective units.</li><li>b. To correct the problem, replace the items identified on the Repeating Defects Page.</li></ol></li><li>4. If the problem continues, replace the transfer belt cleaner. If you replace the transfer belt cleaner, reset the counter:<ol data-bbox="708 842 1484 1171" style="list-style-type: none"><li>a. At the control panel, press <b>Log In</b>. Enter system administrator login information, then touch <b>Done</b>. For details, refer to the <i>System Administrator Guide</i>.</li><li>b. Touch <b>Device &gt; Tools &gt; Device Settings</b>.</li><li>c. Scroll, then touch <b>Supplies &gt; Supply Counter Reset</b>.</li><li>d. Touch <b>Transfer Belt Cleaner</b>.</li><li>e. Touch <b>Confirm Reset</b>.</li><li>f. To close the pop-up window, touch <b>X</b>, touch <b>admin</b>, then select <b>Logout</b>.</li></ol></li></ol>

## Solving Print-Quality Problems (continued)

Problem	Solution
<p><b>Poor Transparency Print Quality</b> Print-quality defects are occurring on transparency film:</p> <ul style="list-style-type: none"><li>• Light or dark spots</li><li>• Smeared toner</li><li>• Light bands on print</li></ul>	<p>Use only Xerox® Transparencies.</p> <p><b>CAUTION:</b> Using non-Xerox® transparencies can cause print-quality problems or damage to the fuser. Damage caused by using unsupported media is not covered by the Xerox® Warranty, Service Agreement, or Total Satisfaction Guarantee.</p>
<p><b>Grays are Not Neutral</b> The grays on the printed page are not neutral; they contain color tints.</p>	<p>Calibrate the printer colors. The calibration process adjusts the printer color balance.</p> <ol style="list-style-type: none"><li>1. At the control panel, touch <b>Device &gt; Tools &gt; Troubleshooting &gt; Calibration &gt; Print Calibration</b>.</li><li>2. Follow the onscreen instructions to run the Print Calibration procedure.</li></ol>
<p><b>Colors Vary Between Computers</b> The colors printed from one computer do not match the colors printed from a different computer.</p>	<ol style="list-style-type: none"><li>1. Confirm that the print driver settings for Print Quality, Color Correction, and Color By Words are identical on both computers.</li><li>2. Adjust the settings as needed.</li></ol> <p><b>Note:</b> Print driver settings override the settings that are made at the printer control panel.</p>
<p><b>Colors Do Not Match</b> The color produced by the printer is different from the color that it must match.</p>	<p>For more information about color matching, go to the Online Support Assistant at <a href="http://www.xerox.com/office/support">www.xerox.com/office/support</a>.</p>
<p><b>Printed Colors Do Not Match Monitor Colors</b> The color produced by the printer looks different from the color that appears on the computer monitor.</p>	<p>To view information about color matching between the monitor and the printed document, go to the Online Support Assistant at <a href="http://www.xerox.com/office/support">www.xerox.com/office/support</a>.</p>

## Print-Quality Settings

The Print-Quality mode and Color Corrections options directly control the quality of your prints. You can change these settings in the print driver. Select the setting that is best suited for your print job.

### Print-Quality Mode

- **Enhanced** mode is the general-purpose mode for crisp, bright color prints. Enhanced mode balances speed with quality.
- **High Resolution** mode is a high-quality mode that creates fine lines and detail. High Resolution mode is recommended for vibrant, saturated color prints. High Resolution mode balances quality over speed.
- **Toner Saver** mode reduces the amount of toner used for print jobs and is useful for draft-quality output. Print quality is slightly lower than using Standard mode.

### Color Corrections

Color corrections are available on the Image Options tab in the print driver. The Preview window appears on the right side of the Image Options tab. When the Preview check box is selected, color correction appears in the Preview window. Selecting and clearing the Preview check box allows you to compare the corrected image to the uncorrected image.

To adjust the color characteristics of your print job, select the Color Correction tab, then select options as needed.

- **Xerox Black and White Conversion** converts the colors to grayscale, producing a black and white print job. This setting is useful for creating black and white master documents for photocopying or faxing.
- **Color Correction** provides options to match the printer colors as closely as possible to colors on other devices, such as your computer screen or a printing press.
  - **Automatic** applies the best color correction to each graphic element of the document: text, artwork, and photographs.
  - **Simulate LCD Display** approximates the print job color to the colors on a LCD computer monitor.
  - **sRGB Display** approximates the print job color to an RGB (red, green, blue) display.
  - **None** removes all color correction. This option is the best choice when working with color specified within your application or operating system.
- **Xerox Automatic Color** applies the best color correction to each graphic element of the document, including text, artwork, and photographs.
- **Custom Automatic Color** provides more options for customizing colors in your print job. Use one selection to adjust the color of the text and graphics. Use the other selection to adjust the color correction applied to images. You can apply a wide range of color options to each element to simulate the outputs of different color devices.

To adjust colors using descriptive phrases, select the **Color By Words** tab. From the menus, select the phrases to build a sentence that describes the color adjustment that you want. You can build more than one sentence for the print job, affecting one color or an entire range of colors.

To change settings for each individual color parameter, select the **Color Adjustments** tab, then adjust the sliders. The sliders allow you to select a continuous range of adjustment for each of the following:

- Lightness
- Contrast
- Saturation
- Cyan to Red
- Magenta to Green
- Yellow to Blue

For more information on color matching and ICC profiles, go to [www.xerox.com/office/support](http://www.xerox.com/office/support).

# Solución de problemas de calidad de impresión

Su impresora multifunción a color Xerox® AltaLink® C8230/C8235/C8245/C8255/C8270 se ha diseñado para realizar impresiones en color de alta calidad de forma sistemática. Si tiene problemas con la calidad de impresión, consulte la información de estas páginas para intentar solucionarlos. Para obtener más información de asistencia en línea, vaya a [www.xerox.com/office/support](http://www.xerox.com/office/support).

**PRECAUCIÓN:** los daños causados por la utilización de papel, transparencias y otros soportes de impresión especiales no recomendados no están cubiertos por la garantía, el acuerdo de servicio ni la Total Satisfaction Guarantee (Garantía de satisfacción total) de Xerox®. La Total Satisfaction Guarantee (Garantía de satisfacción total) está disponible en Estados Unidos y Canadá. La cobertura puede variar fuera de estas zonas geográficas. Póngase en contacto con su representante local si desea más información.

## Tipo de papel

**PRECAUCIÓN:** si cambia el tipo de papel de una bandeja, cámbielo también en el panel de control para que coincida. Si no cambia el tipo de papel, podría generar problemas de calidad de impresión o dañar el fusor.

Para obtener los mejores resultados, utilice solo papel y material de impresión de Xerox® recomendados. El papel y material de impresión de Xerox® están garantizados para proporcionar resultados excelentes en la impresora multifunción a color Xerox® AltaLink® C8230/C8235/C8245/C8255/C8270. Para pedir el papel y material de impresión de Xerox®, vaya a [www.xerox.com/office/supplies](http://www.xerox.com/office/supplies).

Para obtener una lista completa del papel recomendado para la impresora, vaya a:

- Norteamérica: [www.xerox.com/rmlna](http://www.xerox.com/rmlna)
- Europa: [www.xerox.com/rmleu](http://www.xerox.com/rmleu)

## Solución de problemas de calidad de impresión

Utilice estas tablas para encontrar soluciones concretas a problemas de calidad de impresión.

**Nota:** las imágenes representan impresiones con alimentación por el borde largo. Si imprime con alimentación por el borde corto, los defectos de calidad de impresión se giran 90 grados. Las imágenes se muestran solo a modo de referencia. No se imprimen todas las páginas representadas.

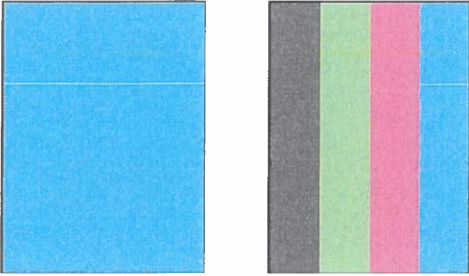
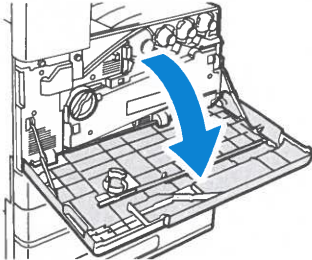
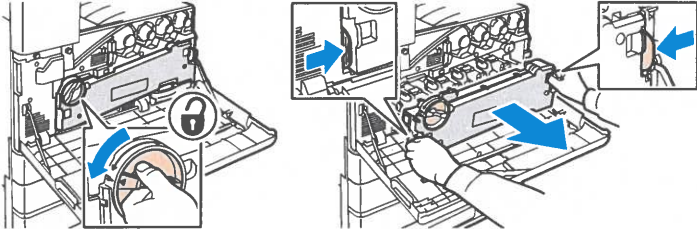
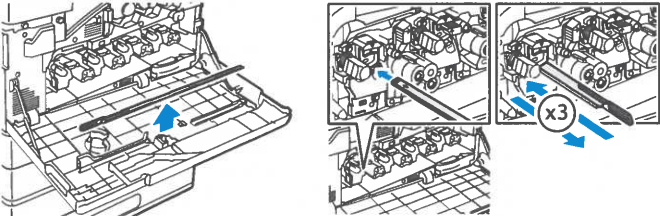

## Solución de problemas de calidad de impresión

Problema	Solución
<p data-bbox="99 220 472 247">Líneas o rayas claras en un color</p> 	<ol data-bbox="662 220 959 625" style="list-style-type: none"><li data-bbox="662 220 959 247">1. Abra la cubierta frontal. </li><li data-bbox="662 537 1495 625">2. Para desbloquear la palanca de tensión de la correa, en el lado izquierdo de la impresora, gire la palanca de tensión de la correa y abra la cubierta del cartucho de cilindro. </li><li data-bbox="662 890 1484 978">3. Tire del limpiador del LED del cabezal de impresión hasta que se detenga y luego introdúzcalo hasta el fondo y sáquelo al máximo dos o tres veces. Repita este procedimiento en las cuatro unidades de tóner. <p data-bbox="699 999 1450 1087"><b>Nota:</b> asegúrese de que saca los limpiadores del LED del cabezal de impresión hasta el tope. Introdúzcalos también hasta su tope. No ejerza demasiada fuerza.</p></li></ol> <p data-bbox="662 1360 1463 1518">Si el problema continúa, compruebe si el cartucho de cilindro es la causa del problema. Para comprobarlo, sustituya el cartucho de cilindro sospechoso con otro cartucho de cilindro de otro color. Si el problema se produce en donde movió el cartucho de cilindro sospechoso, sustituya el cartucho de cilindro sospechoso.</p>

## Solución de problemas de calidad de impresión (continuación)

Problema	Solución
<p><b>Fusión incompleta</b> Parece que falta tóner en la impresión o se desprende con facilidad.</p> 	<ol style="list-style-type: none"><li>1. Compruebe que el papel utilizado es del tipo correcto para la impresora y que se ha colocado correctamente. Para obtener una lista completa del papel recomendado para la impresora, vaya a:<ul style="list-style-type: none"><li>– Norteamérica: <a href="http://www.xerox.com/rmlna">www.xerox.com/rmlna</a></li><li>– Europa: <a href="http://www.xerox.com/rmleu">www.xerox.com/rmleu</a></li></ul></li><li>2. Compruebe que el tipo de papel se ha seleccionado en el panel de control y en el controlador de impresión.</li><li>3. Si el problema continúa, realice una de las acciones siguientes:<ol style="list-style-type: none"><li>a. Para las bandejas exclusivas, inicie sesión como administrador, seleccione <b>Dispositivo &gt; Herramientas &gt; Configuración del dispositivo &gt; Administración de papel &gt; Configuración de bandeja</b>. Seleccione la bandeja, pulse <b>Editar</b> y cambie el tipo de papel. <b>Nota:</b> inicie sesión como administrador del sistema para modificar el tamaño, tipo y color del papel en una bandeja exclusiva cuando el panel de control está bloqueado.</li><li>b. Para las bandejas configuradas como completamente ajustables:<ul style="list-style-type: none"><li>• Bandejas 1–4 y 6: abra y cierre la bandeja de papel seleccionada.</li><li>• Bandeja 5: retire el papel y vuelva a insertarlo.</li></ul>El panel de control solicita que confirme o cambie el tipo de papel.</li><li>c. En la pantalla táctil, pulse <b>Tipo</b> y elija una de estas acciones:<ul style="list-style-type: none"><li>• Seleccione el tipo correcto de papel y pulse <b>Confirmar</b>.</li><li>• Seleccione el siguiente tipo de papel con más peso y pulse <b>Confirmar</b>.</li></ul></li></ol> <b>Nota:</b> los tipos de papel del más ligero al más pesado son:<ul style="list-style-type: none"><li>• Para papel sin estucar: Común, Cartulina ligera, Cartulina y Cartulina gruesa.</li><li>• Para papel estucado: Cartulina ligera brillante, Cartulina brillante y Cartulina gruesa brillante.</li></ul></li></ol>

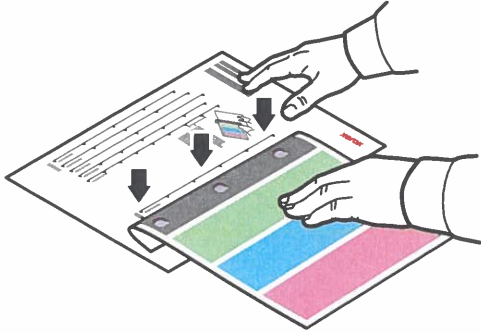

## Solución de problemas de calidad de impresión (continuación)

Problema	Solución
<p><b>Defectos repetitivos</b></p> <p>Aparecen puntos o líneas en la página a intervalos regulares, en la dirección en que se desplaza el papel en la impresora, en todos los colores o en áreas no impresas de la página.</p>  <p>Aparecen puntos o líneas en la página a intervalos regulares, en la dirección en que se desplaza el papel en la impresora, solo en un color.</p> 	<ol style="list-style-type: none"><li>1. En el panel de control, pulse <b>Dispositivo &gt; Herramientas &gt; Solución de problemas &gt; Páginas de asistencia &gt; Página defectos repetitivos &gt; Imprimir</b>. Se imprimirá la Página de defectos que se repiten, con indicaciones para identificar las unidades defectuosas.</li><li>2. Cambie los elementos identificados por la página Defectos repetitivos para resolver el problema.</li><li>3. si sustituyó el rodillo de transferencia, restaure el contador:<ol style="list-style-type: none"><li>a. En el panel de control, pulse <b>Conexión</b>. Introduzca los datos de conexión del administrador del sistema y pulse <b>Intro</b>. Si desea más información, consulte la <i>Guía del administrador del sistema</i>.</li><li>b. Pulse <b>Dispositivo &gt; Herramientas &gt; Opciones del dispositivo</b>.</li><li>c. Desplácese y pulse <b>Suministros &gt; Restauración del contador de suministros</b>.</li><li>d. Pulse <b>Segundo rodillo de transferencia de polarización</b>.</li><li>e. Pulse <b>Restaurar contador</b>.</li><li>f. Para cerrar la ventana emergente, pulse <b>X</b>, pulse <b>admin</b>, y seleccione <b>Desconexión</b>.</li></ol></li></ol> 

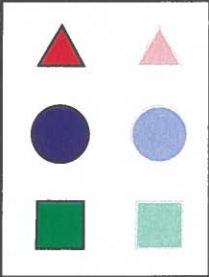
## Solución de problemas de calidad de impresión (continuación)

Problema	Solución
<p><b>Desplazamiento de imagen</b></p> <p>El desplazamiento más habitual se produce cuando el tóner parece estar reimpresso en la página a unos 95 mm (3.75 pulg.) en la dirección en que se desplaza el papel en la impresora.</p> <p><b>Nota:</b> si la distancia es diferente, utilice la página Efectos repetitivos para identificar la causa.</p> 	<ol style="list-style-type: none"><li>1. Compruebe que el papel utilizado es del tipo correcto para la impresora y que se ha colocado correctamente. Para obtener una lista completa del papel recomendado para la impresora, vaya a:<ul style="list-style-type: none"><li>– Norteamérica: <a href="http://www.xerox.com/rmlna">www.xerox.com/rmlna</a></li><li>– Europa: <a href="http://www.xerox.com/rmleu">www.xerox.com/rmleu</a></li></ul></li><li>2. Compruebe que el tipo de papel se ha seleccionado en el panel de control y en el controlador de impresión. <b>Nota:</b> inicie sesión como administrador del sistema para modificar el tamaño, tipo y color del papel en una bandeja exclusiva cuando el panel de control está bloqueado.</li><li>3. Si el problema continúa, realice una de las acciones siguientes:<ol style="list-style-type: none"><li>a. Para las bandejas exclusivas, inicie sesión como administrador, seleccione <b>Dispositivo &gt; Herramientas &gt; Configuración del dispositivo &gt; Administración de papel &gt; Configuración de bandeja</b>. Seleccione la bandeja, pulse <b>Editar</b> y cambie el tipo de papel.</li><li>b. Para las bandejas configuradas como completamente ajustables:<ul style="list-style-type: none"><li>• Bandejas 1–4 y 6: abra y cierre la bandeja de papel seleccionada.</li><li>• Bandeja 5: retire el papel y vuelva a insertarlo.</li></ul>El panel de control solicita que confirme o cambie el tipo de papel.</li><li>c. En la pantalla táctil, pulse <b>Tipo</b> y elija una de estas acciones:<ul style="list-style-type: none"><li>• Seleccione el tipo correcto de papel y pulse <b>Confirmar</b>.</li><li>• Seleccione el siguiente tipo de papel con más peso y pulse <b>Confirmar</b>.</li></ul><b>Nota:</b> los tipos de papel del más ligero al más pesado son:<ul style="list-style-type: none"><li>• Para papel sin estucar: Común, Cartulina ligera, Cartulina y Cartulina gruesa.</li><li>• Para papel estucado: Cartulina ligera brillante, Cartulina brillante y Cartulina gruesa brillante.</li></ul></li><li>d. Para identificar la causa, utilice la página Defectos repetitivos. Para obtener más información, consulte la página anterior.</li></ol></li></ol>

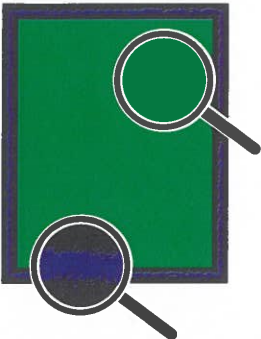
## Solución de problemas de calidad de impresión (continuación)

Problema	Solución
<p><b>Colores sólidos con motas o manchas</b> <b>Los negros aparecen azules</b></p> 	<ol style="list-style-type: none"><li>1. Compruebe que el papel utilizado es del tipo correcto para la impresora y que se ha colocado correctamente. Para obtener una lista completa del papel recomendado para la impresora, vaya a:<ul style="list-style-type: none"><li>– Norteamérica: <a href="http://www.xerox.com/rmlna">www.xerox.com/rmlna</a></li><li>– Europa: <a href="http://www.xerox.com/rmleu">www.xerox.com/rmleu</a></li></ul></li><li>2. Compruebe que el tipo de papel se ha seleccionado en el panel de control y en el controlador de impresión.</li></ol> <p>Si el problema continúa, solicite asistencia técnica.</p>
<p><b>Colores alineados incorrectamente</b> El color se desplaza fuera del área designada o se le superpone otro color.</p> 	<p>Abra y cierre la puerta frontal. La impresora realiza una calibración de registro automática con la siguiente impresión.</p>
<p><b>Todos los colores demasiado claros o demasiado oscuros</b> Los colores aparecen descoloridos o demasiado oscuros en la impresión o la copia.</p>	<ol style="list-style-type: none"><li>1. Compruebe que el papel utilizado es del tipo correcto para la impresora y que se ha colocado correctamente. Para obtener una lista completa del papel recomendado para la impresora, vaya a:<ul style="list-style-type: none"><li>– Norteamérica: <a href="http://www.xerox.com/rmlna">www.xerox.com/rmlna</a></li><li>– Europa: <a href="http://www.xerox.com/rmleu">www.xerox.com/rmleu</a></li></ul></li><li>2. Compruebe que el tipo de papel se ha seleccionado en el panel de control y en el controlador de impresión.</li><li>3. Calibre los colores de la impresora. El procedimiento de calibración ajusta el nivel de claridad y el equilibrio de colores en la impresora. En el panel de control, pulse <b>Dispositivo &gt; Herramientas &gt; Solución de problemas &gt; Calibración &gt; Calibración de impresión</b> o <b>Calibración de copia</b>. Siga las instrucciones en pantalla para realizar el procedimiento de calibración.</li></ol> <p><b>Nota:</b> consulte el capítulo <i>Impresión</i> de la <i>Guía del usuario</i> para obtener información sobre el cambio del valor de Claridad en el controlador PostScript de la impresora del sistema operativo que esté utilizando.</p>

## Solución de problemas de calidad de impresión (continuación)

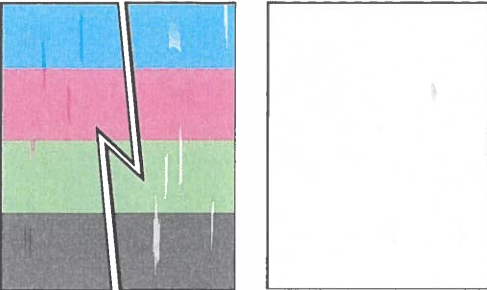
Problema	Solución
<p data-bbox="99 220 380 247"><b>Líneas, manchas o rayas</b></p> <p data-bbox="99 260 607 321">Aparecen marcas oscuras o claras en todos los colores y en áreas no impresas de la página.</p> 	<ol data-bbox="670 220 1498 1262" style="list-style-type: none"><li>1. Compruebe que el papel utilizado es del tipo correcto para la impresora y que se ha colocado correctamente. Para obtener una lista completa del papel recomendado para la impresora, vaya a:<ul data-bbox="708 369 1179 436" style="list-style-type: none"><li>– Norteamérica: <a href="http://www.xerox.com/rmlna">www.xerox.com/rmlna</a></li><li>– Europa: <a href="http://www.xerox.com/rmleu">www.xerox.com/rmleu</a></li></ul></li><li>2. Compruebe que el tipo de papel se ha seleccionado en el panel de control y en el controlador de impresión.</li><li>3. Si el problema persiste, siga estos pasos:<ol data-bbox="708 569 1487 779" style="list-style-type: none"><li>a. En el panel de control, pulse <b>Dispositivo</b> &gt; <b>Páginas de información</b> &gt; <b>Solución de problemas de calidad de impresión</b> &gt; <b>Imprimir</b>. Se imprimirá la Página de defectos que se repiten, con indicaciones para identificar las unidades defectuosas.</li><li>b. Cambie los elementos identificados por la página Defectos repetitivos para resolver el problema.</li></ol></li><li>4. Si el problema continúa, sustituya el limpiador de la correa de transferencia. Si sustituye el limpiador de la correa de transferencia, restaure el contador:<ol data-bbox="708 898 1498 1262" style="list-style-type: none"><li>a. En el panel de control, pulse <b>Conexión</b>. Introduzca los datos de conexión del administrador del sistema y pulse <b>Hecho</b>. Si desea más información, consulte la <i>Guía del administrador del sistema</i>.</li><li>b. Pulse <b>Dispositivo</b> &gt; <b>Herramientas</b> &gt; <b>Opciones del dispositivo</b>.</li><li>c. Desplácese y pulse <b>Suministros</b> &gt; <b>Restauración del contador de suministros</b>.</li><li>d. Pulse <b>Limpiador de la correa de transferencia</b>.</li><li>e. Pulse <b>Confirmar restauración</b>.</li><li>f. Para cerrar la ventana emergente, pulse <b>X</b>, pulse <b>admin</b>, y seleccione <b>Desconexión</b>.</li></ol></li></ol>

## Solución de problemas de calidad de impresión (continuación)

Problema	Solución
<p><b>Mala calidad de impresión en transparencias</b></p> <p>Se producen defectos de calidad al imprimir en transparencias de poliéster:</p> <ul style="list-style-type: none"><li>• Puntos claros u oscuros</li><li>• Manchas de tóner</li><li>• Bandas claras</li></ul>	<p>Utilice únicamente transparencias de Xerox®.</p> <p><b>PRECAUCIÓN:</b> el uso de transparencias que no sean de Xerox® puede generar problemas de calidad de impresión o dañar el fusor. Los daños causados por la utilización de soportes de impresión no recomendados no están cubiertos por la garantía, el acuerdo de servicio ni la Total Satisfaction Guarantee (Garantía de satisfacción total) de Xerox®.</p>
<p><b>Grisés no neutros</b></p> <p>Los grises impresos en la página no son neutros, sino que contienen tintas de color.</p>	<p>Calibre los colores de la impresora. El proceso de calibración ajusta el equilibrio de colores en la impresora.</p> <ol style="list-style-type: none"><li>1. En el panel de control, pulse <b>Dispositivo &gt; Herramientas &gt; Solución de problemas &gt; Calibración &gt; Calibración de la impresión.</b></li><li>2. Siga las instrucciones en pantalla para realizar una calibración de impresión.</li></ol>
<p><b>El color varía de un equipo informático a otro</b></p> <p>Los colores impresos desde una estación de trabajo no coinciden con los impresos desde otra estación.</p>	<ol style="list-style-type: none"><li>1. Confirme que las opciones del controlador de impresión de Calidad de impresión, de Corrección de color y de Color en palabras son iguales en ambos equipos.</li><li>2. Ajuste los valores según proceda.</li></ol> <p><b>Nota:</b> los ajustes del controlador prevalecen sobre los realizados en el panel de control de la impresora.</p>
<p><b>Los colores no se corresponden</b></p> <p>El color que produce la impresora es distinto del ajustado.</p>	<p>Si desea obtener más información sobre la concordancia de colores, vaya al Asistente de Ayuda en línea en <a href="http://www.xerox.com/office/support">www.xerox.com/office/support</a>.</p>
<p><b>Los colores impresos no coinciden con los del monitor</b></p> <p>El color que produce la impresora parece distinto al que aparece en el monitor del equipo.</p>	<p>Para ver información sobre la concordancia de colores entre el monitor y el documento impreso, visite el Asistente de Ayuda en línea en <a href="http://www.xerox.com/office/support">www.xerox.com/office/support</a>.</p>

## Opciones de calidad de impresión

La calidad de las impresiones está directamente controlada por el Modo de calidad de impresión y las opciones de Correcciones del color. Puede cambiar estas opciones en el controlador de impresión. Seleccione la opción que mejor se ajuste a su trabajo de impresión.

### Modo de calidad de impresión

- **Mejorado** es un modo de uso general para unas impresiones en color más frescas y brillantes. El modo Mejorado combina la velocidad con la calidad.
- **Alta resolución** es un modo de alta calidad que crea líneas finas y nítidas. El modo Alta resolución se recomienda para impresiones en color vibrantes y saturadas. El modo Alta resolución equilibra la calidad sobre la velocidad.
- **Ahorro de tóner** reduce la cantidad de tóner utilizado para imprimir trabajos y es muy útil para la salida con calidad de borrador. La calidad de impresión es ligeramente inferior a la del modo Estándar.

### Correcciones del color

Las correcciones del color están disponibles en la pestaña Opciones de la imagen en el controlador de impresión. La ventana Vista previa aparece en el lado derecho de la pestaña Opciones de la imagen. Cuando se ha seleccionado la casilla de verificación Vista previa, la corrección del color aparece en la ventana Vista previa. Al seleccionar y quitar la marca de selección de la marca de verificación Vista previa, se puede comparar la imagen corregida con la imagen original.

Para ajustar las características del color de su trabajo de impresión, seleccione la pestaña Corrección del color y, a continuación, seleccione las opciones necesarias.

- **Conversión a blanco y negro de Xerox** convierte los colores a escala de grises y produce un trabajo de impresión en blanco y negro. Esta opción es útil para crear páginas maestras a blanco y negro para fotocopiar o enviar por fax.
- **Corrección del color** proporciona opciones para generar una correspondencia de colores en la impresora tan cercana como sea posible con los colores de otros dispositivos, por ejemplo, la pantalla del equipo o una prensa.
  - **Automático** aplica la mejor corrección del color a cada elemento gráfico del documento: textos, ilustraciones y fotografías.
  - **Simular pantalla LCD** aproxima el color del trabajo de impresión a los colores del monitor LCD del equipo.
  - **Pantalla sRGB** aproxima el color del trabajo de impresión a una pantalla RGB (rojo, verde, azul).
  - **No** elimina todas las correcciones del color. Es la mejor opción al trabajar con un color especificado en la aplicación o sistema operativo.
- **Color automático de Xerox** aplica la mejor corrección del color a cada elemento gráfico del documento: textos, ilustraciones y fotografías.
- **Color automático personalizado** proporciona más opciones de colores personalizados en el trabajo de impresión. Utilice una opción para ajustar el color del texto y de los gráficos. Utilice la otra opción para ajustar la corrección del color aplicada a las imágenes. Cada elemento se puede controlar con varios controles de color para simular las impresiones de distintos dispositivos de color.

Para ajustar los colores usando frases descriptivas, seleccione la pestaña **Color en palabras**. Seleccione una opción en los menús para formar una frase que describa el ajuste de color deseado. Puede formar más de una frase que se aplique al trabajo de impresión y que afecte un color o varios colores.

Para cambiar las opciones de cada parámetro de color, seleccione la pestaña **Ajustes de color** y, a continuación, ajuste los controles deslizantes. Los controles deslizantes permiten seleccionar ajustes continuos para cada una de las opciones siguientes:

- Claridad
- Contraste
- Saturación
- Cian a rojo
- Magenta a verde
- Amarillo a azul

Para obtener más información sobre la concordancia de colores y los perfiles ICC, vaya a [www.xerox.com/office/support](http://www.xerox.com/office/support).

# Résolution des problèmes de qualité d'impression

Votre imprimante multifonctions couleur Xerox® AltaLink® C8230/C8235/C8245/C8255/C8270 est conçue pour garantir durablement des impressions de haute qualité. Si vous observez des problèmes de qualité d'impression, utilisez les informations de ce document pour les résoudre. Pour des informations d'assistance en ligne détaillées, accédez à [www.xerox.com/office/support](http://www.xerox.com/office/support).

**ATTENTION** : la garantie, le contrat de maintenance ou le programme Total Satisfaction Guarantee (Garantie de satisfaction totale) Xerox® ne couvre pas les dommages causés par l'utilisation de papier, transparents ou autres supports spéciaux non pris en charge. Le programme Total Satisfaction Guarantee (Garantie de satisfaction totale) est disponible aux États-Unis et au Canada. La couverture peut varier dans les autres pays. Pour plus de détails, contactez votre représentant.

## Type de papier

**ATTENTION** : si vous changez le type de papier dans un magasin, vous devez aussi changer le type de papier sur le panneau de commande pour qu'il corresponde au papier présent dans le magasin. Si le type de papier n'est pas changé, des problèmes de qualité d'impression peuvent survenir et le module four peut être endommagé.

Pour les meilleurs résultats, utilisez uniquement le papier et les supports Xerox® recommandés. Le papier et les supports Xerox® garantissent d'excellents résultats sur votre imprimante multifonctions couleur Xerox® AltaLink® C8230/C8235/C8245/C8255/C8270. Pour commander du papier et des supports Xerox®, accédez à [www.xerox.com/office/supplies](http://www.xerox.com/office/supplies).

Pour la liste complète des supports recommandés pour votre imprimante, rendez-vous sur les sites suivants :

- Amérique du Nord : [www.xerox.com/rmlna](http://www.xerox.com/rmlna)
- Europe : [www.xerox.com/rmleu](http://www.xerox.com/rmleu)

## Résolution des problèmes de qualité d'impression

Utilisez les tableaux suivants pour obtenir des solutions spécifiques aux problèmes de qualité d'impression.

**Remarque** : les images représentent des impressions effectuées départ grand côté. Si vous imprimez départ petit côté, une rotation de 90 degrés est appliquée aux défauts de qualité image. Ces images sont utilisées à des fins de référence uniquement. Toutes les pages représentées ne sont pas imprimées.

## Résolution des problèmes de qualité d'impression

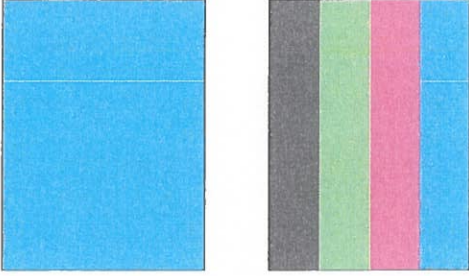
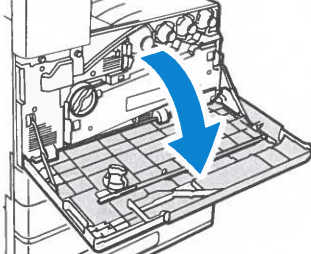
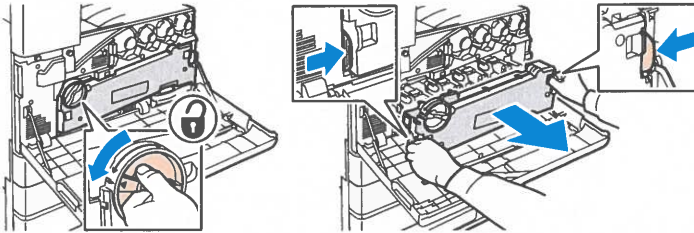
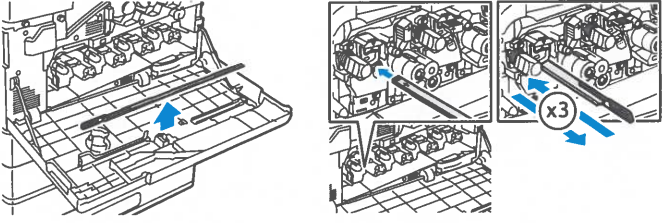
Problème	Solution
<p data-bbox="99 220 519 247"><b>Lignes ou stries claires - Une couleur</b></p> 	<p data-bbox="662 220 982 247">1. Ouvrez le panneau avant.</p>  <p data-bbox="662 535 1477 630">2. Pour déverrouiller le levier de tension de la courroie, sur le côté gauche de l'imprimante, tournez le levier de tension de la courroie, puis ouvrez le panneau des modules photorécepteurs.</p>  <p data-bbox="662 892 1485 987">3. Sortez le nettoyeur de tête d'impression LED jusqu'à ce qu'il s'arrête, puis repoussez-le jusqu'au fond. Reprenez cette opération deux ou trois fois. Effectuez cette procédure pour les quatre modules.</p> <p data-bbox="698 997 1477 1092"><b>Remarque :</b> sortez les nettoyeurs de tête d'impression LED aussi loin que possible. Repoussez-les aussi loin que possible. N'exercez pas trop de force.</p>  <p data-bbox="662 1354 1485 1491">Si le problème persiste, vérifiez si le module photorécepteur est à l'origine du problème. Pour vérifier, échangez le module photorécepteur avec un autre module d'une autre couleur. Si le problème se produit à l'endroit où vous avez placé le module, remplacez-le.</p>

## Résolution des problèmes de qualité d'impression (suite)

Problème	Solution
<p><b>Fixation incomplète</b> Le toner est absent de l'impression ou s'en détache facilement.</p> 	<p>1. Vérifiez que le papier que vous utilisez est de type approprié à l'imprimante et qu'il est chargé correctement.</p> <p>Pour la liste complète des supports recommandés pour votre imprimante, rendez-vous sur les sites suivants :</p> <ul style="list-style-type: none"><li>– Amérique du Nord : <a href="http://www.xerox.com/rmlna">www.xerox.com/rmlna</a></li><li>– Europe : <a href="http://www.xerox.com/rmleu">www.xerox.com/rmleu</a></li></ul> <p>2. Vérifiez que le type de papier est sélectionné à la fois sur le panneau de commande et dans le pilote d'imprimante.</p> <p>3. Si le problème persiste, effectuez l'une des opérations suivantes :</p> <p>a. Pour les magasins spécialisés, connectez-vous en tant qu'admin, touchez <b>Périphérique &gt; Outils &gt; Paramètres du périphérique &gt; Gestion des supports &gt; Paramètres magasin</b>. Sélectionnez le magasin, touchez <b>Modifier</b>, puis changez le type de papier.</p> <p><b>Remarque :</b> pour changer le format, le type ou la couleur du papier d'un magasin spécialisé lorsque le panneau de commande est verrouillé, connectez-vous en tant qu'administrateur système.</p> <p>b. Pour les magasins définis sur Entièrement réglable :</p> <ul style="list-style-type: none"><li>• Magasins 1–4 et 6 : Ouvrez et fermez le magasin sélectionné.</li><li>• Magasin 5 : Retirez, puis réinsérez le papier.</li></ul> <p>Le panneau de commande vous invite à confirmer ou changer le type de papier.</p> <p>c. Sur l'écran tactile, appuyez sur <b>Type</b> puis effectuez une des actions suivantes :</p> <ul style="list-style-type: none"><li>• Sélectionnez le type de papier approprié puis appuyez sur <b>Confirmer</b>.</li><li>• Sélectionnez le type de papier de grammage supérieur le plus proche puis appuyez sur <b>Confirmer</b>.</li></ul> <p><b>Remarque :</b> Types de support des plus fins aux plus épais :</p> <ul style="list-style-type: none"><li>• Supports non couchés : Standard, Support cartonné fin, Support cartonné et Support cartonné épais.</li><li>• Supports couchés : Support cartonné glacé fin, Support cartonné glacé et Support cartonné épais.</li></ul>

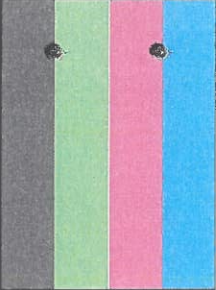
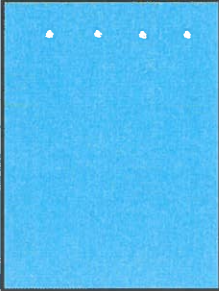
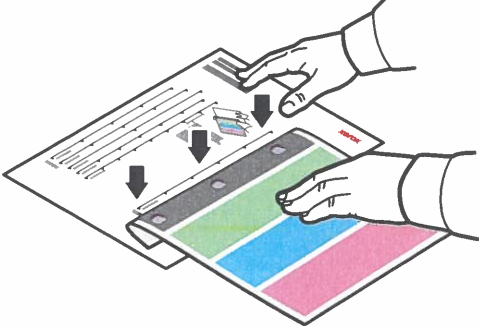

## Résolution des problèmes de qualité d'impression (suite)

Problème	Solution
<p><b>Défauts à répétition</b></p> <p>Des taches ou des lignes apparaissent à intervalles réguliers sur la page, dans le sens de déplacement du papier dans l'imprimante, dans toutes les couleurs ou dans des zones non imprimées.</p>  <p>Des taches ou des lignes apparaissent à intervalles réguliers sur la page, dans le sens de déplacement du papier dans l'imprimante, dans une seule couleur.</p> 	<ol style="list-style-type: none"><li>1. Sur le panneau de commande, appuyez sur <b>Périphérique &gt; Outils &gt; Dépannage &gt; Pages de support &gt; Page des défauts répétés &gt; Imprimer</b>. La page des défauts répétés qui s'imprime contient des instructions permettant d'identifier les unités défectueuses.</li><li>2. Pour corriger le problème, remplacez les composants identifiés sur la page des défauts répétés. </li><li>3. Si vous avez remplacé le rouleau de transfert, réinitialisez le compteur :<ol style="list-style-type: none"><li>a. Sur le panneau de commande, appuyez sur la touche <b>Connexion</b>. Entrez les informations de connexion de l'administrateur système, puis appuyez sur <b>Entrer</b>. Pour plus d'informations, reportez-vous au <i>Guide de l'administrateur système</i>.</li><li>b. Appuyez sur <b>Périphérique &gt; Outils &gt; Paramètres du périphérique</b>.</li><li>c. Faites défiler l'écran puis appuyez sur <b>Consommables &gt; Réinitialisation du compteur de module remplaçable</b>.</li><li>d. Appuyez sur <b>Rouleau de deuxième transfert</b>.</li><li>e. Appuyez sur <b>Réinitialiser compteur</b>.</li><li>f. Pour fermer la fenêtre contextuelle, appuyez sur <b>X, admin</b>, puis <b>Déconnexion</b>.</li></ol></li></ol>

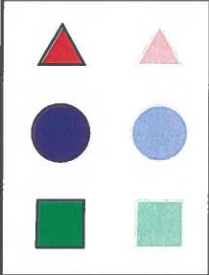
## Résolution des problèmes de qualité d'impression (suite)

Problème	Solution
<p><b>Décaler l'image</b></p> <p>Le décalage le plus fréquent est lorsque le toner semble être réimprimé sur la page et placé à environ 95 mm (3,75 pouces) sur toute la page dans le sens de déplacement du papier dans l'imprimante.</p> <p><b>Remarque :</b> pour une distance différente, utilisez la page des défauts répétés pour identifier la cause.</p> 	<ol style="list-style-type: none"><li>1. Vérifiez que le papier que vous utilisez est du type approprié à l'imprimante et qu'il est chargé correctement. Pour la liste complète des supports recommandés pour votre imprimante, rendez-vous sur les sites suivants :<ul style="list-style-type: none"><li>– Amérique du Nord : <a href="http://www.xerox.com/rmlna">www.xerox.com/rmlna</a></li><li>– Europe : <a href="http://www.xerox.com/rmleu">www.xerox.com/rmleu</a></li></ul></li><li>2. Vérifiez que le type de papier est sélectionné à la fois sur le panneau de commande et dans le pilote d'imprimante. <b>Remarque :</b> pour changer le format, le type ou la couleur du papier d'un magasin spécialisé lorsque le panneau de commande est verrouillé, connectez-vous en tant qu'administrateur système.</li><li>3. Si le problème persiste, effectuez l'une des opérations suivantes :<ol style="list-style-type: none"><li>a. Pour les magasins spécialisés, connectez-vous en tant qu'admin, touchez <b>Périphérique</b> &gt; <b>Outils</b> &gt; <b>Paramètres du périphérique</b> &gt; <b>Gestion des supports</b> &gt; <b>Paramètres magasin</b>. Sélectionnez le magasin, touchez <b>Modifier</b>, puis changez le type de papier.</li><li>b. Pour les magasins définis sur Entièrement réglable :<ul style="list-style-type: none"><li>• Magasins 1–4 et 6 : Ouvrez et fermez le magasin sélectionné.</li><li>• Magasin 5 : Retirez, puis réinsérez le papier.</li></ul>Le panneau de commande vous invite à confirmer ou changer le type de papier.</li><li>c. Sur l'écran tactile, appuyez sur <b>Type</b> puis effectuez une des actions suivantes :<ul style="list-style-type: none"><li>• Sélectionnez le type de papier approprié puis appuyez sur <b>Confirmer</b>.</li><li>• Sélectionnez le type de papier de grammage supérieur le plus proche puis appuyez sur <b>Confirmer</b>.</li></ul><b>Remarque :</b> Types de support des plus fins aux plus épais :<ul style="list-style-type: none"><li>• Supports non couchés : Standard, Support cartonné fin, Support cartonné et Support cartonné épais.</li><li>• Supports couchés : Support cartonné glacé fin, Support cartonné glacé et Support cartonné épais.</li></ul></li><li>d. Identifiez la cause à l'aide de la page des défauts répétés. Pour de plus amples informations, reportez-vous à la page précédente.</li></ol></li></ol>

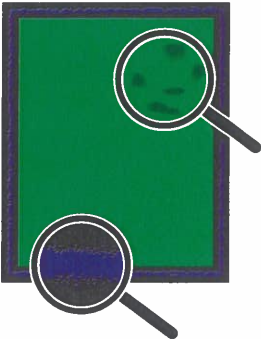
## Résolution des problèmes de qualité d'impression (suite)

Problème	Solution
<p>Les zones de couverture importantes semblent tachetées ou marbrées</p> <p>Les zones noires apparaissent bleues</p> 	<ol style="list-style-type: none"><li>1. Vérifiez que le papier que vous utilisez est de type approprié à l'imprimante et qu'il est chargé correctement. Pour la liste complète des supports recommandés pour votre imprimante, rendez-vous sur les sites suivants :<ul style="list-style-type: none"><li>– Amérique du Nord : <a href="http://www.xerox.com/rmlna">www.xerox.com/rmlna</a></li><li>– Europe : <a href="http://www.xerox.com/rmleu">www.xerox.com/rmleu</a></li></ul></li><li>2. Vérifiez que le type de papier est sélectionné à la fois sur le panneau de commande et dans le pilote d'imprimante.</li></ol> <p>Si le problème persiste, contactez le Centre Services Xerox.</p>
<p><b>Alignement incorrect des couleurs</b></p> <p>La couleur se trouve en dehors de la zone désignée ou est surimposée sur une autre couleur.</p> 	<p>Ouvrez puis refermez le panneau avant. L'imprimante effectue un étalonnage automatique de l'alignement des couleurs au cours de la prochaine impression.</p>
<p><b>Toutes les couleurs sont trop claires ou trop foncées</b></p> <p>Les couleurs semblent délavées ou trop foncées sur les impressions ou les copies.</p>	<ol style="list-style-type: none"><li>1. Vérifiez que le papier que vous utilisez est de type approprié à l'imprimante et qu'il est chargé correctement. Pour la liste complète des supports recommandés pour votre imprimante, rendez-vous sur les sites suivants :<ul style="list-style-type: none"><li>– Amérique du Nord : <a href="http://www.xerox.com/rmlna">www.xerox.com/rmlna</a></li><li>– Europe : <a href="http://www.xerox.com/rmleu">www.xerox.com/rmleu</a></li></ul></li><li>2. Vérifiez que le type de papier est sélectionné à la fois sur le panneau de commande et dans le pilote d'imprimante.</li><li>3. Étalonnez les couleurs de l'imprimante. La procédure d'étalonnage règle l'équilibre et le niveau de luminosité des couleurs de l'imprimante. Sur le panneau de commande, touchez <b>Périphérique &gt; Outils &gt; Dépannage &gt; Étalonnage &gt; Étalonnage impression</b> ou <b>Étalonnage copie</b>. Suivez les instructions pour exécuter la procédure d'étalonnage.</li></ol> <p><b>Remarque :</b> pour plus d'informations sur le changement du paramètre Luminosité dans le pilote d'impression PostScript pour votre système d'exploitation, reportez-vous au chapitre <i>Impression</i> du <i>Guide de l'utilisateur</i>.</p>

## Résolution des problèmes de qualité d'impression (suite)

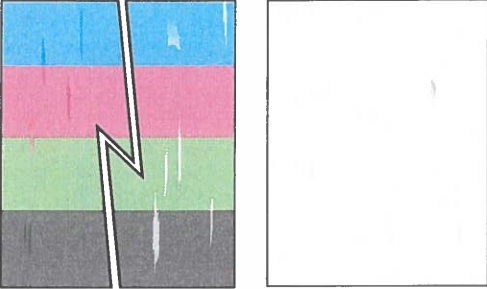
Problème	Solution
<p data-bbox="99 212 431 239"><b>Lignes, salissures ou traînées</b></p> <p data-bbox="99 254 607 344">Des zones sombres ou claires apparaissent sur la page dans toutes les couleurs et/ou dans des zones non imprimables.</p> 	<p data-bbox="667 212 1386 270">1. Vérifiez que le papier que vous utilisez est de type approprié à l'imprimante et qu'il est chargé correctement.</p> <p data-bbox="704 285 1370 344">Pour la liste complète des supports recommandés pour votre imprimante, rendez-vous sur les sites suivants :</p> <ul data-bbox="704 359 1235 428" style="list-style-type: none"><li data-bbox="704 359 1235 386">– Amérique du Nord : <a href="http://www.xerox.com/rmlna">www.xerox.com/rmlna</a></li><li data-bbox="704 401 1105 428">– Europe : <a href="http://www.xerox.com/rmleu">www.xerox.com/rmleu</a></li></ul> <p data-bbox="667 443 1495 501">2. Vérifiez que le type de papier est sélectionné à la fois sur le panneau de commande et dans le pilote d'imprimante.</p> <p data-bbox="667 516 1252 543">3. Si le problème n'est pas résolu, suivez ces étapes :</p> <ul data-bbox="704 558 1463 653" style="list-style-type: none"><li data-bbox="704 558 1463 653">a. Sur le panneau de commande, appuyez sur <b>Périphérique</b> &gt; <b>Pages d'informations</b> &gt; <b>Page Résolution d'incidents de qualité d'impression</b> &gt; <b>Imprimer</b>.</li></ul> <p data-bbox="742 667 1490 726">La page des défauts répétés qui s'imprime contient des instructions permettant d'identifier les unités défectueuses.</p> <ul data-bbox="704 741 1495 800" style="list-style-type: none"><li data-bbox="704 741 1495 800">b. Pour corriger le problème, remplacez les composants identifiés sur la page des défauts répétés.</li></ul> <p data-bbox="667 814 1490 905">4. Si le problème persiste, remplacez le nettoyeur de la courroie de transfert. Si vous avez remplacé le nettoyeur de la courroie de transfert, réinitialisez le compteur :</p> <ul data-bbox="704 919 1474 1318" style="list-style-type: none"><li data-bbox="704 919 1474 1045">a. Sur le panneau de commande, appuyez sur la touche <b>Connexion</b>. Entrez les informations de connexion de l'administrateur système, puis appuyez sur <b>Terminé</b>. Pour plus d'informations, reportez-vous au <i>Guide de l'administrateur système</i>.</li><li data-bbox="704 1060 1474 1087">b. Appuyez sur <b>Périphérique</b> &gt; <b>Outils</b> &gt; <b>Paramètres du périphérique</b>.</li><li data-bbox="704 1102 1354 1161">c. Faites défiler l'écran puis appuyez sur <b>Consommables</b> &gt; <b>Réinitialisation du compteur de module remplaçable</b>.</li><li data-bbox="704 1176 1312 1203">d. Appuyez sur <b>Nettoyeur de la courroie de transfert</b>.</li><li data-bbox="704 1218 1003 1245">e. Appuyez sur <b>Confirmer</b>.</li><li data-bbox="704 1260 1435 1318">f. Pour fermer la fenêtre contextuelle, appuyez sur <b>X, admin</b>, puis <b>Déconnexion</b>.</li></ul>

## Résolution des problèmes de qualité d'impression (suite)

Problème	Solution
<p><b>Mauvaise qualité d'impression sur les transparents</b></p> <p>Des défauts de qualité d'impression apparaissent sur les films transparents :</p> <ul style="list-style-type: none"><li>• Taches claires ou foncées</li><li>• Salissures de toner</li><li>• Bandes claires sur les impressions</li></ul>	<p>Utilisez uniquement des transparents Xerox®.</p> <p><b>ATTENTION :</b> l'utilisation de transparents non-Xerox® peut causer des problèmes de qualité d'impression ou endommager le module four. Les dommages causés par l'utilisation de supports non pris en charge ne sont pas couverts par la garantie, le contrat de maintenance et le programme Total Satisfaction Guarantee (Garantie de satisfaction totale) Xerox®.</p>
<p><b>Gris non neutres</b></p> <p>Les gris imprimés sur la page ne sont pas neutres, ils contiennent de la couleur.</p>	<p>Étalonnez les couleurs de l'imprimante. La procédure d'étalonnage règle l'équilibre des couleurs de l'imprimante.</p> <ol style="list-style-type: none"><li>1. Sur le panneau de commande, appuyez sur <b>Périphérique &gt; Outils &gt; Dépannage &gt; Étalonnage &gt; Étalonnage impression.</b></li><li>2. Suivez les instructions qui apparaissent à l'écran pour lancer la procédure d'étalonnage règle l'équilibre.</li></ol>
<p><b>Les couleurs varient d'un ordinateur à l'autre</b></p> <p>Les couleurs imprimées depuis un ordinateur ne correspondent pas aux couleurs imprimées depuis un autre ordinateur.</p>	<ol style="list-style-type: none"><li>1. Vérifiez si les paramètres de pilote d'imprimante pour la qualité d'impression, la correction des couleurs et la description des couleurs sont identiques sur les deux ordinateurs.</li><li>2. Réglez les paramètres si nécessaire.</li></ol> <p><b>Remarque :</b> les paramètres du pilote ont priorité sur les paramètres sélectionnés sur le panneau de commande de l'imprimante.</p>
<p><b>Les couleurs ne correspondent pas</b></p> <p>La couleur produite par l'imprimante est différente de la couleur qu'elle doit reproduire.</p>	<p>Pour plus d'informations sur la correspondance des couleurs, accédez à l'Assistant de support en ligne à l'adresse <a href="http://www.xerox.com/office/support">www.xerox.com/office/support</a>.</p>
<p><b>Les couleurs imprimées ne correspondent pas aux couleurs affichées sur l'écran d'ordinateur</b></p> <p>La couleur produite par l'imprimante semble différente de la couleur affichée à l'écran.</p>	<p>Pour obtenir des informations sur la correspondance des couleurs entre l'écran et le document imprimé, accédez à l'Assistant de support en ligne sur <a href="http://www.xerox.com/office/support">www.xerox.com/office/support</a>.</p>

## Paramètres de qualité d'impression

Le mode de qualité d'impression et les options de correction des couleurs contrôlent directement la qualité des impressions. Vous pouvez modifier ces paramètres dans le pilote d'impression. Sélectionnez le paramètre le mieux adapté à votre travail d'impression.

### Mode de qualité d'impression

- Le mode **Avancé** est un mode polyvalent pour des impressions nettes aux couleurs vives. Le mode avancé équilibre la vitesse et la qualité.
- Le mode **Haute résolution** est un mode haute qualité qui produit des lignes fines et beaucoup de détails. Le mode haute résolution est recommandé pour les impressions couleur saturées, vives. Le mode haute résolution donne priorité à la qualité plutôt qu'à la vitesse.
- Le mode **Économie de toner** réduit la quantité de toner utilisée pour les travaux d'impression et est utile pour une qualité d'impression brouillon. La qualité d'impression est légèrement inférieure au mode standard.

### Correction des couleurs

La correction des couleurs est disponible dans l'onglet Options Image du pilote d'impression. La fenêtre Aperçu apparaît sur le côté droit de l'onglet Options Image. Lorsque la case Aperçu est sélectionnée, la correction des couleurs apparaît dans la fenêtre Aperçu. La sélection et la désélection de la case Aperçu vous permet de comparer l'image corrigée avec l'image initiale.

Pour régler les paramètres couleur de votre travail d'impression, sélectionnez l'onglet Correction des couleurs, puis sélectionnez les options requises.

- **Conversion noir et blanc Xerox** convertit les couleurs en échelle de gris, produisant un travail d'impression noir et blanc. Ce paramètre est utile pour créer des originaux noir et blanc pour la copie ou le fax.
- **Correction des couleurs** propose des options pour faire correspondre les couleurs de l'imprimante avec les couleurs d'autres périphériques tels que l'écran de votre ordinateur ou une presse.
  - **Automatique** applique la meilleure correction des couleurs à chaque élément graphique du document : texte, illustrations et photographies.
  - **Simuler un affichage LCD** utilise des couleurs proches de celles d'un écran LCD pour la couleur du travail d'impression.
  - **Affichage sRVB** utilise des couleurs proches de celles d'un affichage RVB (rouge, vert, bleu) pour la couleur du travail d'impression.
  - **Aucune** supprime toutes les corrections de couleur. Ce paramètre est particulièrement approprié lorsque la couleur est spécifiée dans l'application ou le système d'exploitation.
- **Couleur automatique Xerox** applique la meilleure correction des couleurs à chaque élément graphique du document : texte, illustrations et photographies.
- **Couleur automatique personnalisée** propose des options supplémentaires permettant de personnaliser les couleurs dans votre travail d'impression. Utilisez une sélection pour régler la couleur du texte et des graphiques. Utilisez l'autre sélection pour régler la correction des couleurs appliquée aux images. Vous pouvez appliquer une large gamme d'options couleur à chaque élément pour simuler les sorties de différents périphériques couleur.

Pour régler les couleurs à l'aide de phrases descriptives, sélectionnez l'onglet **Description des couleurs**. Dans les menus, sélectionnez les phrases décrivant le mieux le réglage des couleurs que vous souhaitez. Vous pouvez construire plusieurs phrases à appliquer au travail d'impression, pour une couleur ou toute une gamme de couleurs.

Pour modifier les réglages de chaque paramètre couleur, sélectionnez l'onglet **Paramètres couleur**, puis déplacez les curseurs. Les curseurs permettent de sélectionner une série de réglages pour chacun des éléments suivants :

- Luminosité
- Contraste
- Saturation
- Cyan > Rouge
- Magenta -> Vert
- Jaune > Bleu

Pour plus d'informations sur la correspondance des couleurs et les profils ICC, accédez à [www.xerox.com/office/support](http://www.xerox.com/office/support).

# Risoluzione dei problemi di qualità di stampa

La stampante multifunzione a colori Xerox® AltaLink® C8230/C8235/C8245/C8255/C8270 è progettata per produrre stampe a colori di alta qualità, giorno dopo giorno. Se si verificano problemi di qualità di stampa, utilizzare le informazioni fornite in queste pagine per risolverli. Per informazioni dettagliate sull'assistenza online, visitare il sito [www.xerox.com/office/support](http://www.xerox.com/office/support).

**ATTENZIONE:** i danni causati dall'utilizzo di carta, trasparenti e altri supporti di stampa speciali non compatibili sono esclusi dalla garanzia Xerox®, dal contratto di manutenzione e dalla Total Satisfaction Guarantee (Garanzia "soddisfatti o rimborsati"). La Total Satisfaction Guarantee (Garanzia "soddisfatti o rimborsati") è disponibile negli Stati Uniti e in Canada. La copertura della garanzia può variare negli altri paesi. Per informazioni dettagliate, rivolgersi al rappresentante locale.

## Tipo di carta

**ATTENZIONE:** se si modifica il tipo di carta nel vassoio, modificare anche il tipo di carta sul pannello comandi in modo che corrispondano. In caso contrario potrebbero verificarsi problemi di qualità di stampa o danni al fusore.

Per risultati ottimali, utilizzare solo carta e supporti di stampa raccomandati da Xerox®. La carta e i supporti Xerox® garantiscono risultati eccellenti sulla stampante multifunzione a colori Xerox® AltaLink® C8230/C8235/C8245/C8255/C8270. Per ordinare carta e supporti Xerox®, andare su [www.xerox.com/office/supplies](http://www.xerox.com/office/supplies).

Per l'elenco completo dei supporti raccomandati per la stampante, visitare i seguenti siti:

- Nord America: [www.xerox.com/rmlna](http://www.xerox.com/rmlna)
- Europa: [www.xerox.com/rmleu](http://www.xerox.com/rmleu)

## Risoluzione dei problemi di qualità di stampa

Utilizzare le tabelle seguenti per trovare soluzioni specifiche a problemi di qualità di stampa.

**Nota:** le immagini visualizzate rappresentano stampe con alimentazione LEF. Se si stampa su carta con alimentazione SEF, i difetti di qualità di stampa vengono ruotati di 90 gradi. Le immagini visualizzate sono solo per riferimento. Non tutte le pagine rappresentate vengono stampate.

## Risoluzione dei problemi di qualità di stampa

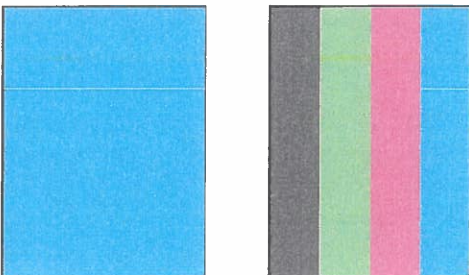
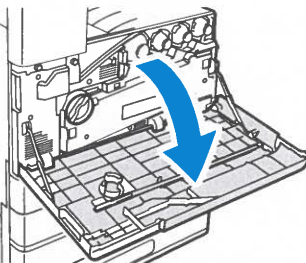
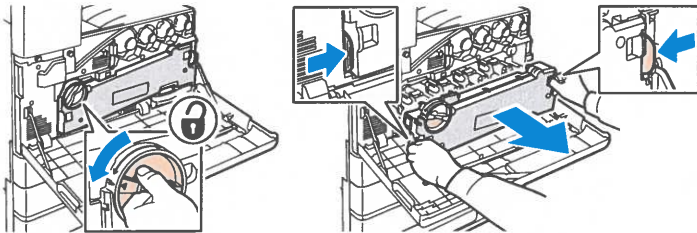
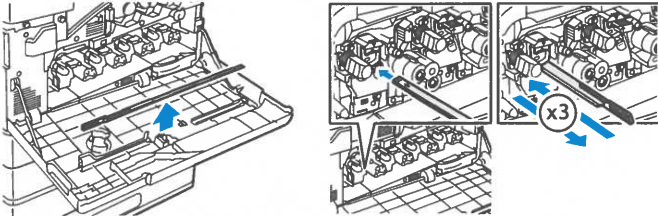
Problema	Soluzione
<p data-bbox="99 212 568 241">Righe o striature chiare in un solo colore</p> 	<ol data-bbox="662 212 1015 241" style="list-style-type: none"><li>1. Aprire la copertura anteriore.</li></ol>  <ol data-bbox="662 527 1448 619" style="list-style-type: none"><li>2. Per sbloccare la leva di tensione della cinghia, sul lato sinistro della stampante, ruotare la leva, quindi aprire la copertura della cartuccia fotoricettore.</li></ol>  <ol data-bbox="662 884 1495 976" style="list-style-type: none"><li>3. Estrarre l'unità di pulizia delle testine di stampa LED finché non si ferma, quindi inserirla ed estrarla completamente due o tre volte. Ripetere questa operazione per tutte e quattro le unità toner.</li></ol> <p data-bbox="701 989 1490 1081"><b>Nota:</b> assicurarsi di estrarre fino in fondo le unità di pulizia delle testine di stampa LED. Spingerle all'interno quanto più possibile facendo attenzione a non forzare eccessivamente.</p>  <p data-bbox="662 1354 1495 1514">Se il problema permane, verificare se a causare il problema è la cartuccia fotoricettore. A tal fine, scambiare la cartuccia fotoricettore che si sospetta sia danneggiata con un'altra cartuccia fotoricettore di un colore diverso. Se il problema si verifica quando si sposta la cartuccia fotoricettore che si sospetta danneggiata, sostituire quest'ultima.</p>

## Risoluzione dei problemi di qualità di stampa (continua)

Problema	Soluzione
<p><b>Fusione incompleta</b> Il toner manca o si stacca facilmente dalla stampa.</p> 	<ol style="list-style-type: none"><li>1. Accertarsi che la carta utilizzata sia di tipo compatibile per la stampante e caricata in modo corretto. Per l'elenco completo dei supporti raccomandati per la stampante, visitare i seguenti siti:<ul style="list-style-type: none"><li>– Nord America: <a href="http://www.xerox.com/rmlna">www.xerox.com/rmlna</a></li><li>– Europa: <a href="http://www.xerox.com/rmleu">www.xerox.com/rmleu</a></li></ul></li><li>2. Controllare che il tipo di carta sia selezionato sul pannello comandi e nel driver di stampa.</li><li>3. Se il problema persiste, eseguire una delle seguenti operazioni:<ol style="list-style-type: none"><li>a. Per i vassoi dedicati, accedere come amministratore, selezionare <b>Dispositivo &gt; Strumenti &gt; Impostazioni dispositivo &gt; Gestione carta &gt; Impostazioni vassoio</b>. Selezionare il vassoio, selezionare <b>Modifica</b>, quindi modificare il tipo di carta. <b>Nota:</b> per modificare il tipo, il formato o il colore di carta in un vassoio dedicato quando il pannello comandi è bloccato, connettersi al sistema come amministratore.</li><li>b. Per i vassoi impostati su Regolabile:<ul style="list-style-type: none"><li>• Vassoi 1–4 e 6: Aprire e chiudere il vassoio carta selezionato.</li><li>• Vassoio 5: Rimuovere e reinserire la carta.</li></ul>Sul pannello comandi viene visualizzato un messaggio che chiede di confermare o modificare il tipo di carta.</li><li>c. Dallo schermo sensibile, toccare <b>Tipo</b>, quindi eseguire una delle operazioni seguenti:<ul style="list-style-type: none"><li>• Selezionare il tipo di carta corretto, quindi toccare <b>Conferma</b>.</li><li>• Selezionare il successivo tipo di carta selezionato, quindi toccare <b>Conferma</b>.</li></ul></li></ol></li></ol> <b>Nota:</b> i tipi di carta dal più leggero al più pesante sono: <ul style="list-style-type: none"><li>• Per la carta non patinata: Standard, Cartoncino leggero, Cartoncino e Cartoncino pesante.</li><li>• Per la carta patinata: Cartoncino lucido leggero, Cartoncino lucido e Cartoncino lucido pesante.</li></ul>

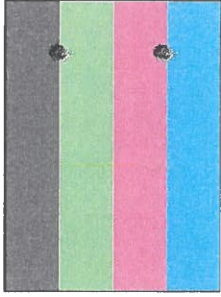
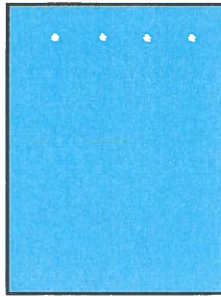
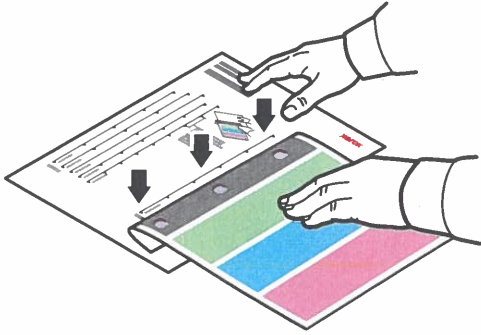

## Risoluzione dei problemi di qualità di stampa (continua)

Problema	Soluzione
<p data-bbox="94 226 267 258"><b>Difetti ripetuti</b></p> <p data-bbox="94 268 597 394">Macchie o righe visualizzate a intervalli regolari sulla pagina, lungo la direzione di alimentazione della carta nella stampante, in tutti i colori e/o nelle aree non stampate.</p>  <p data-bbox="94 720 589 846">Macchie o righe visualizzate a intervalli regolari sulla pagina, lungo la direzione di alimentazione della carta nella stampante, e in un unico colore.</p> 	<ol data-bbox="670 226 1490 1241" style="list-style-type: none"><li>1. Dal pannello comandi, toccare <b>Dispositivo &gt; Strumenti &gt; Problemi e soluzioni &gt; Pagine di assistenza &gt; Pagina difetti ripetuti &gt; Stampa</b>. Viene stampata la Pagina difetti ripetuti con istruzioni per l'identificazione delle unità difettose.</li><li>2. Per correggere il problema, sostituire i componenti identificati sulla Pagina difetti ripetuti. </li><li>3. Se è stato sostituito il rullo di trasferimento, ripristinare il contatore:<ol data-bbox="704 842 1490 1241" style="list-style-type: none"><li>a. Sul pannello comandi, premere <b>Accedi</b>. Immettere le informazioni di accesso dell'amministratore di sistema e toccare <b>Invio</b>. Per ulteriori informazioni, vedere la <i>System Administrator Guide (Guida per l'amministratore del sistema)</i>.</li><li>b. Toccare <b>Dispositivo &gt; Strumenti &gt; Impostazioni dispositivo</b>.</li><li>c. Scorrere e toccare <b>Materiali di consumo &gt; Azzeramento contatore materiali di consumo</b>.</li><li>d. Toccare <b>Secondo rullo di trasf. polarizzato</b>.</li><li>e. Toccare <b>Ripristina contatore</b>.</li><li>f. Per chiudere la finestra pop-up, toccare <b>X</b>, toccare <b>admin</b>, quindi selezionare <b>Logout</b>.</li></ol></li></ol>

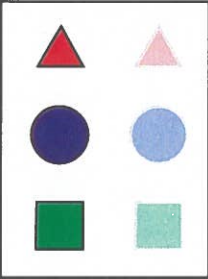
## Risoluzione dei problemi di qualità di stampa (continua)

Problema	Soluzione
<p><b>Sfalsamento immagine</b></p> <p>Lo sfalsamento più comune si ha quando il toner appare ristampato sulla pagina e posizionato a circa 95 mm (3,75 poll.) nella pagina nella direzione di alimentazione della carta nella stampante.</p> <p><b>Nota:</b> per una distanza diversa, fare riferimento alla Pagina difetti ripetuti per identificare la causa.</p> 	<ol style="list-style-type: none"><li>1. Accertarsi che la carta utilizzata sia di tipo compatibile per la stampante e caricata in modo corretto. Per l'elenco completo dei supporti raccomandati per la stampante, visitare i seguenti siti:<ul style="list-style-type: none"><li>– Nord America: <a href="http://www.xerox.com/rmlna">www.xerox.com/rmlna</a></li><li>– Europa: <a href="http://www.xerox.com/rmleu">www.xerox.com/rmleu</a></li></ul></li><li>2. Controllare che il tipo di carta sia selezionato sul pannello comandi e nel driver di stampa. <b>Nota:</b> per modificare il tipo, il formato o il colore di carta in un vassoio dedicato quando il pannello comandi è bloccato, connettersi al sistema come amministratore.</li><li>3. Se il problema persiste, eseguire una delle seguenti operazioni:<ol style="list-style-type: none"><li>a. Per i vassoi dedicati, accedere come amministratore, selezionare <b>Dispositivo &gt; Strumenti &gt; Impostazioni dispositivo &gt; Gestione carta &gt; Impostazioni vassoio</b>. Selezionare il vassoio, selezionare <b>Modifica</b>, quindi modificare il tipo di carta.</li><li>b. Per i vassoi impostati su Regolabile:<ul style="list-style-type: none"><li>• Vassoi 1–4 e 6: Aprire e chiudere il vassoio carta selezionato.</li><li>• Vassoio 5: Rimuovere e reinserire la carta.</li></ul>Sul pannello comandi viene visualizzato un messaggio che chiede di confermare o modificare il tipo di carta.</li><li>c. Dallo schermo sensibile, toccare <b>Tipo</b>, quindi eseguire una delle operazioni seguenti:<ul style="list-style-type: none"><li>• Selezionare il tipo di carta corretto, quindi toccare <b>Conferma</b>.</li><li>• Selezionare il successivo tipo di carta selezionato, quindi toccare <b>Conferma</b>.</li></ul></li></ol><b>Nota:</b> i tipi di carta dal più leggero al più pesante sono:<ul style="list-style-type: none"><li>• Per la carta non patinata: Standard, Cartoncino leggero, Cartoncino e Cartoncino pesante.</li><li>• Per la carta patinata: Cartoncino lucido leggero, Cartoncino lucido e Cartoncino lucido pesante.</li></ul></li><li>d. Per identificare la causa, fare riferimento alla Pagina difetti ripetuti. Per informazioni dettagliate, fare riferimento alla pagina precedente.</li></ol>

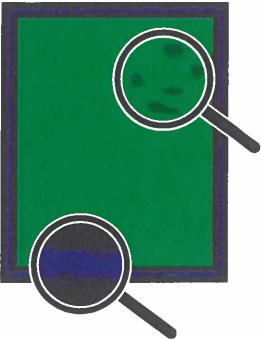
## Risoluzione dei problemi di qualità di stampa (continua)

Problema	Soluzione
<p><b>Aree con alta copertura appaiono chiazze</b> Le aree nere sembrano blu</p> 	<ol style="list-style-type: none"><li>1. Accertarsi che la carta utilizzata sia di tipo compatibile per la stampante e caricata in modo corretto. Per l'elenco completo dei supporti raccomandati per la stampante, visitare i seguenti siti:<ul style="list-style-type: none"><li>– Nord America: <a href="http://www.xerox.com/rmlna">www.xerox.com/rmlna</a></li><li>– Europa: <a href="http://www.xerox.com/rmleu">www.xerox.com/rmleu</a></li></ul></li><li>2. Controllare che il tipo di carta sia selezionato sul pannello comandi e nel driver di stampa.</li></ol> <p>Se il problema persiste, richiedere assistenza.</p>
<p><b>Allineamento colori errato</b> Il colore si è spostato al di fuori dell'area designata o è sovrapposto a un altro colore.</p> 	<p>Aprire e chiudere lo sportello anteriore. La stampante esegue una calibratura di registrazione automatica con la stampa successiva.</p>
<p><b>Tutti i colori sono troppo chiari o troppo scuri</b> I colori appaiono sbiaditi o troppo scuri sulla stampa o sulla copia.</p>	<ol style="list-style-type: none"><li>1. Accertarsi che la carta utilizzata sia di tipo compatibile per la stampante e caricata in modo corretto. Per l'elenco completo dei supporti raccomandati per la stampante, visitare i seguenti siti:<ul style="list-style-type: none"><li>– Nord America: <a href="http://www.xerox.com/rmlna">www.xerox.com/rmlna</a></li><li>– Europa: <a href="http://www.xerox.com/rmleu">www.xerox.com/rmleu</a></li></ul></li><li>2. Controllare che il tipo di carta sia selezionato sul pannello comandi e nel driver di stampa.</li><li>3. Calibrare i colori della stampante. La procedura di calibrazione consente di regolare il bilanciamento del colore e il livello di luminosità della stampante. Sul pannello comandi, selezionare <b>Dispositivo &gt; Strumenti &gt; Risoluzione dei problemi &gt; Calibrazione &gt; Calibrazione stampa</b> o <b>Calibrazione copia</b>. Seguire le istruzioni su schermo per eseguire la procedura di calibrazione.</li></ol> <p><b>Nota:</b> per informazioni sulla modifica dell'impostazione di Luminosità nel driver di stampa PostScript per il proprio sistema operativo, fare riferimento al capitolo <i>Stampa della Guida per l'utente</i>.</p>

## Risoluzione dei problemi di qualità di stampa (continua)

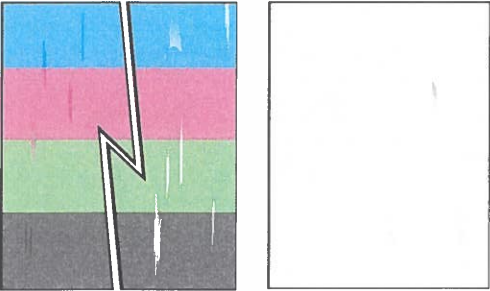
Problema	Soluzione
<p><b>Righe, sbavature o striature</b></p> <p>Segni chiari e/o scuri appaiono in modo uniforme in tutti i colori e/o nelle aree non stampate.</p> 	<ol style="list-style-type: none"><li>1. Accertarsi che la carta utilizzata sia di tipo compatibile per la stampante e caricata in modo corretto. Per l'elenco completo dei supporti raccomandati per la stampante, visitare i seguenti siti:<ul style="list-style-type: none"><li>– Nord America: <a href="http://www.xerox.com/rmlna">www.xerox.com/rmlna</a></li><li>– Europa: <a href="http://www.xerox.com/rmleu">www.xerox.com/rmleu</a></li></ul></li><li>2. Controllare che il tipo di carta sia selezionato sul pannello comandi e nel driver di stampa.</li><li>3. Se il problema persiste, procedere come segue:<ol style="list-style-type: none"><li>a. Da pannello comandi, toccare <b>Dispositivo &gt; Pagine di informazioni &gt; Pagina risoluzione dei problemi di qualità di stampa &gt; Stampa</b>. Viene stampata la Pagina difetti ripetuti con istruzioni per l'identificazione delle unità difettose.</li><li>b. Per correggere il problema, sostituire i componenti identificati sulla Pagina difetti ripetuti.</li></ol></li><li>4. Se il problema persiste, sostituire l'unità di pulizia della cinghia di trasferimento. Se si sostituisce l'unità di pulizia della cinghia di trasferimento, ripristinare il contatore:<ol style="list-style-type: none"><li>a. Sul pannello comandi, premere <b>Accedi</b>. Immettere le informazioni di accesso dell'amministratore di sistema e toccare <b>Fatto</b>. Per ulteriori informazioni, vedere la <i>System Administrator Guide (Guida per l'amministratore del sistema)</i>.</li><li>b. Toccare <b>Dispositivo &gt; Strumenti &gt; Impostazioni dispositivo</b>.</li><li>c. Scorrere e toccare <b>Materiali di consumo &gt; Azzeramento contatore materiali di consumo</b>.</li><li>d. Toccare <b>Pulitore cinghia di trasferimento</b>.</li><li>e. Toccare <b>Conferma reimpostazione</b>.</li><li>f. Per chiudere la finestra pop-up, toccare <b>X</b>, toccare <b>admin</b>, quindi selezionare <b>Logout</b>.</li></ol></li></ol>

## Risoluzione dei problemi di qualità di stampa (continua)

Problema	Soluzione
<p><b>Qualità di stampa scadente sui trasparenti</b> Difetti di qualità di stampa si verificano sui trasparenti:</p> <ul style="list-style-type: none"><li>• Punti chiari o scuri</li><li>• Sbavature di toner</li><li>• Bande chiare sulla stampa</li></ul>	<p>Usare solo trasparenti Xerox®.</p> <p><b>ATTENZIONE:</b> l'uso di trasparenti non Xerox® può causare problemi di qualità di stampa o danneggiare il fusore. I danni causati dall'utilizzo di supporti non approvati sono esclusi dalla garanzia Xerox®, dal contratto di manutenzione o dalla Total Satisfaction Guarantee (Garanzia "soddisfatti o rimborsati").</p>
<p><b>Grigi non neutri</b> I grigi sulla pagina stampata non sono neutri; contengono sfumature di colore.</p>	<p>Calibrare i colori della stampante. La procedura di calibratura consente di registrare il bilanciamento del colore della stampante.</p> <ol style="list-style-type: none"><li>1. Dal pannello comandi, toccare <b>Dispositivo &gt; Strumenti &gt; Problemi e soluzioni &gt; Calibratura &gt; Calibratura stampa</b>.</li><li>2. Per eseguire la procedura di Calibratura stampa, seguire le istruzioni sullo schermo.</li></ol>
<p><b>I colori variano tra i computer</b> I colori stampati da un computer non corrispondono a quelli stampati da un altro computer.</p>	<ol style="list-style-type: none"><li>1. Verificare che le impostazioni di Qualità di stampa, Correzione colore e Colora in base a parole del driver di stampa siano identiche su entrambi i computer.</li><li>2. Regolare le impostazioni come richiesto.</li></ol> <p><b>Nota:</b> le impostazioni del driver di stampa annullano quelle effettuate sul pannello comandi della stampante.</p>
<p><b>I colori non corrispondono</b> Il colore prodotto dalla stampante è diverso dal colore a cui deve corrispondere.</p>	<p>Per informazioni dettagliate sulla corrispondenza dei colori, accedere al Supporto in linea all'indirizzo <a href="http://www.xerox.com/office/support">www.xerox.com/office/support</a>.</p>
<p><b>I colori stampati non corrispondono ai colori del monitor</b> Il colore prodotto dalla stampante è diverso dal colore visualizzato sul monitor.</p>	<p>Per visualizzare informazioni sulla corrispondenza dei colori fra il monitor e il documento stampato, accedere al Supporto in linea all'indirizzo <a href="http://www.xerox.com/office/support">www.xerox.com/office/support</a>.</p>

## Impostazioni di Qualità di stampa

La qualità delle stampe può essere regolata direttamente utilizzando la modalità Qualità di stampa e le opzioni di Correzione colore. È possibile modificare tali impostazioni nel driver di stampa. Selezionare l'impostazione più adatta al proprio lavoro di stampa.

### Modalità di qualità di stampa

- La modalità **Avanzata** è una modalità di utilizzo generale per stampe a colori nitide e brillanti. Offre un giusto equilibrio tra velocità e qualità.
- La modalità **Alta risoluzione** è una modalità ad alta qualità che consente di riprodurre linee fini e dettagli. È raccomandata per ottenere stampe con colori saturi e vivaci. La modalità Alta risoluzione privilegia la qualità rispetto alla velocità.
- La modalità **Risparmio toner** consente di ridurre la quantità di toner utilizzata per lavori di stampa ed è utile per copie di qualità bozza. La qualità di stampa è leggermente inferiore rispetto alla modalità Standard.

### Correzione colori

Le correzioni colore sono disponibili nella scheda Opzioni immagine sul driver di stampa. La finestra Anteprema appare sul lato destro della scheda Opzioni immagine. Se la casella di controllo Anteprema è selezionata, la correzione colore viene visualizzata nella finestra Anteprema. Per confrontare l'immagine prima e dopo la correzione, selezionare e deselezionare la casella di controllo Anteprema.

Per regolare le caratteristiche colore del lavoro di stampa, selezionare la scheda Correzione colore, quindi selezionare le opzioni in base alle esigenze.

- **Conversione bianco e nero Xerox** converte i colori nella scala di grigi, producendo lavori di stampa in bianco e nero. L'impostazione è utile per creare documenti master in bianco e nero da fotocopiare o inviare via fax.
- **Correzione colore** fornisce le opzioni per ottenere la corrispondenza migliore tra i colori della stampante e quelli di altri dispositivi, ad esempio schermi di computer o macchine tipografiche.
  - **Automatico** applica la miglior correzione colore a ciascun elemento grafico del documento: testo, grafica e fotografie.
  - **Simula display LCD** avvicina i colori della stampa il più possibile a quelli dello schermo LCD di un computer.
  - **Display sRGB** avvicina i colori della stampa il più possibile a quelli di un display RGB (rosso, verde e blu).
  - **No** rimuove tutte le correzioni del colore. È l'opzione migliore quando il colore viene specificato da un'applicazione o dal sistema operativo.
- **Colore automatico Xerox** applica la quantità di correzione colore a ciascun elemento grafico del documento, come testo, grafica e fotografie.
- **Colore automatico personalizzato** offre ulteriori opzioni per personalizzare i colori nel lavoro di stampa. Utilizzare una selezione per registrare il colore di testo e grafica. Utilizzare l'altra selezione per regolare la correzione colore applicata alle immagini. È possibile applicare un'ampia gamma di opzioni colore a ciascun elemento per simulare i risultati ottenibili da dispositivi diversi.

Per regolare i colori utilizzando frasi descrittive, selezionare la scheda **Colora in base a parole**. Dai menu, selezionare le parole per comporre una frase che descriva la regolazione del colore desiderata. È possibile comporre più frasi da applicare al lavoro, per un solo colore o un'intera gamma.

Per modificare le impostazioni dei parametri di ciascun colore, selezionare la scheda **Regolazione colore**, quindi regolare i cursori di scorrimento. I cursori di scorrimento consentono di selezionare una gamma di registrazioni continue per ciascuna delle seguenti opzioni:

- Luminosità
- Contrasto
- Saturazione
- Ciano-Rosso
- Magenta-Giallo
- Giallo-Blu

Per ulteriori informazioni sulla corrispondenza colore e i profili ICC, andare su [www.xerox.com/office/support](http://www.xerox.com/office/support).